



# INDUSTRIAL GAS EQUIPMENT AND WELDING PRODUCTS

EDITION 1/2012

**GCE**  
Security in action

## GCE IN GLOBAL LEAD



### GCE BUSINESS IN GENERAL

GCE's main business originally concentrated on the oxy-acetylene cutting and welding market, but with almost 100 years of experience in the handling of high pressure gases, the product range has grown rapidly.

Today's product portfolio fits a large variety of applications, from simple pressure regulators and blowpipes for welding and cutting to highly sophisticated gas supply systems for the medical and electronics industry and analytical laboratory equipment.

### GCE GROUP INCLUDES FOUR BUSINESS AREAS:

- Cutting & Welding
- Process Applications
- Medical
- High Purity

### ORIGINS

The origins of GCE (Gas Control Equipment) go back as far as the beginning of the twentieth century when oxy-acetylene cutting and welding methods were first invented. GCE group as an independent entity was formed in 1987 through the merging of gas equipment activities by two of the world's leading industrial gas and welding equipment companies into one independent entity. The GCE Group has grown rapidly since its establishment and is leading the restructuring of the European gas-equipment industry through mergers and acquisitions. Through the years, GCE Group's R&D work has resulted in innovative solutions that have quickly become field standards.

### GCE SERVICES

GCE's main customers in industrial area are wholesalers and local distributors, though in some markets gas companies also distribute equipment and cooperate with GCE Group. For these companies we provide local commercial support, professional support and marketing activities. Key end-customers such as shipyards, repair shops and OEM customers, such as welding machine manufacturers, account for a significant part of the sales volume.

### A COMPLETE RANGE FOR CUTTING & WELDING

GCE Group is one of the world's leading producers of industrial regulators for cutting and welding. The range covers a broad spectrum of products, for different applications, that have been designed according to the requirements of most European standards such as DIN, Afnor, BSI and Nordic.

The torch range includes products for heating, cutting, brazing and flame-cleaning applications designed in accordance with the preferences of individual markets and customers. Regulators, torches, nozzles and other products are also increasingly combined in sets and sold to users as a single package.

GCE Group is a pioneer in the field of safety equipment and currently produces a comprehensive range of flashback arrestors and hose check valves. A range of nozzles, including the longlife Coolex® nozzle, completes GCE's Cutting & Welding range.

GCE Group's ranges include various types of gas equipment enabling safe handling of gases in central gas supply systems and brewery equipment, to machine cutting products. We offer cylinder valves and combination valves, pressure control units, gas manifolds, outlet points, shut-off valves, alarm and safety units, high-pressure flexible hoses and accessories for different applications, gases, pressures and flow rates.

All products have to meet demanding requirements for rugged durability, leak-proof sealing and overall safety. Uniquely qualified in this area, GCE stands at the forefront of international development of these products.

### GLOBAL LEADER IN OXY-FUEL TECHNOLOGY

With extensive experience in the development and production of machine cutting torches and cutting nozzles, GCE Group is a global leader in oxy-fuel cutting technology. The design of the products is based on GCE's extensive knowledge and expertise in the oxy-fuel area.

## CONTENT

### PRODUCT SELECTION GUIDE

Light duty cutting system.....	4
Medium duty cutting system.....	5
Heavy duty cutting system.....	5
Light duty welding system.....	6
Heavy duty welding system.....	6
Heating system.....	7

### PRESSURE REGULATORS

Unicontrol Cylinder Regulators .....	10
Fixicontrol Cylinder Regulators .....	12
S2+ MULTISTAGE Cylinder Regulators .....	14
JetControl 600 High Pressure Cylinder Regulators .....	16
CR-60 High Flow Cylinder Regulators .....	18
Special Purpose Regulators .....	20

### FLASHBACK ARRESTORS

Hose Checkvalves .....	24
FR20 .....	24
FR34 .....	25
FR91N.....	25
FR50 .....	26
Manifold Flashback Arrestors.....	26

### TORCHES AND NOZZLES

Orbit Combined Torch .....	30
MK3 Combined Torch.....	33
NM250 Cutting Torch .....	35
Cutting Torch Accessories.....	36
Jetsoud Welding Torch.....	37
Cutting Nozzles .....	38
Welding and Heating Nozzles .....	40
Welding, Cutting and Heating Data .....	41
Straightening, Cleaning and Heating Torches.....	42
Shanks .....	42
Flame Straightening Torches .....	43
Cleaning Torches .....	44
Heating Torches Acetylene - Oxygen .....	46
Heating Torches Propan / Natural Gas - Oxygen.....	48

PROPALINE - PROPANE RANGE .....	54
---------------------------------	----

ACCESSORIES RANGE .....	58
-------------------------	----

## OUR INTERNAL SALES ORGANIZATION



FOR INFORMATION ON:> ADVANCEMENT / CHANGE ORDERS> RETURNS> BILLING

### GCE INDIA HEAD OFFICE AND SERVICE CENTER

,Prem-Bagh' 1st floor  
31 Benson Road, Benson Town  
**Bangalore 560046, Karnataka**

Tel/Fax: +91 80 23631685

email: [gce.india@gcegroup.com](mailto:gce.india@gcegroup.com)

### GCE INDIA REPRESENTATION OFFICE

Offices No. 44 & 45, 2nd Floor,  
Crystal Plaza, Hiranandani Complex,  
Sector - 7, Kharghar, **Navi Mumbai. 410 210,**  
**Maharashtra, India**

Mobile: +91-9987026546

email: [gce.india@gcegroup.com](mailto:gce.india@gcegroup.com)



# GENERAL BUSINESS TERMS AND CONDITIONS

## 1. GENERAL AND CONCLUSION OF AGREEMENT

1. Unless otherwise agreed in writing, our deliveries shall be subject exclusively to the conditions below. On receipt of the goods at the latest, our General Terms and conditions shall be taken as accepted. The customer's purchasing terms and conditions are hereby expressly excluded, nor shall they commit us in any way even if they are not expressly excluded at the time of conclusion of the Agreement. In the event of amendments or other subsidiary agreements, the remaining conditions shall retain their full validity.
2. Our offers are always without obligation. In order to be valid, all transactions, orders and other agreements require our confirmation in writing. Our written order confirmation or agreement shall determine the nature and scope of the delivery.

## 2. PRICE AND INVOICING, TERMS OF PAYMENT ETC.

1. Our normal terms of payment are as follows: full amount in advance.
2. Unless otherwise agreed, our prices are to be understood in Indian Rupee, ex works, Bangalore, excluding packaging.
3. The customer may only set off payment against counterclaims which are undisputed or legally determined.
4. In the event that payment schedules are not maintained, interest of 3 % above the respective EURIBOR interest rate for 3 months.
5. Where payment by bill of exchange is agreed, said bill will only be accepted for payment purposes; in particular, the existing retention of title shall not be affected. In the event that cheques or bills of exchange have not been encashed, either in whole or in part, by the date on which invoices are due for payment, all our unpaid claims shall be due immediately, even where bills of exchange with later due date have been submitted. We shall only be obliged to make further deliveries if the entire unpaid balance is settled immediately and if cash in advance is provided for the entire amount of the goods to be delivered.

## 3. RETENTION OF TITLE

1. Title shall be retained on all delivered goods (reserve items) until all claims against the customer, for whatever legal reason, have been met in full. This is also then applicable when separate claims or our claims have been included in a current invoice and the account has been balanced and accepted. Any contingent treatment or processing of the reserve items shall be performed by the purchaser on behalf of the seller, without any obligation being placed on the latter as a result. In the event that the reserve items are joined, blended or processed by the customer with other items which do not belong to us, we shall have title to the new object in the proportion of the value of the reserve item to the other items used for joining or processing at the time of such joining or processing.
2. Claims owing to the customer through further sale are herewith already assigned to us together with all accessory claims. In the event of the sale of reserve items together with other items or the sale of processed reserve items the claim is herewith assigned to the extent of our invoice amount for the reserve items.
3. In the event of resale abroad, the entire invoice amount shall be due for payment before the goods leave the country.
4. Excess Safeguarding Clause. Provided that the existing collateral security exceeds the debt claims to be secured by more than 15 %, the seller shall undertake to release the appertaining security to the purchaser upon request.

## 4. DELIVERY SCHEDULE AND UNFORESEEN CIRCUMSTANCES

1. The schedule for deliveries and performance shall begin on the day on which agreement is reached between the customer and the supplier in writing. Maintenance of this schedule is subject to provision in due course of all documents, authorisation and releases, to be supplied by the customer, the acceptance and approval of plans, observance of agreed payment schedules and other obligations. In the event that these conditions are not met punctually, the delivery schedule may be extended accordingly.
2. The delivery schedule is deemed to have been maintained if the goods are ready for delivery or fetched within the agreed delivery and performance schedule. In the event that delivery is delayed at the fault of the customer, the delivery schedule is deemed to have been met if the Supplier notifies readiness for dispatch within the said schedule.
3. In the event of unforeseen hindrances outside of our control which occur either with us or with our own suppliers, such as force majeure, transport disruptions, strikes and lockouts and other operating disruptions which we are unable to prevent, the delivery schedule shall be extended accordingly.
4. In the event that the customer does not collect the ordered goods within 14 days of notification of readiness for dispatch or after shipment, we shall be entitled, after allowing an additional period of 14 days, to withdraw from the Agreement and/or claim for damages on account of non-fulfilment.
5. In the event that dispatch of the ordered goods is delayed at the request of the customer and with our agreement, he shall be charged for the costs of storage in our factory, a minimum of 0.5 % of the invoice value, for every month or part thereof, starting from the month following notification of readiness for dispatch.
6. If the customer suffers damage because we are in arrears with the delivery, he shall be entitled to demand a lump-sum compensation for damage resulting from delay. It shall be 0.5% for each full week of delay, however altogether a maximum of 5% of the value of the portion of the overall delivery that cannot be used in due time or not at all pursuant to the contract as a result of the delay. If the customer grants us an appropriate period for performance because of the delay in delivery taking the legal exceptions into consideration and if we do not comply with the period, the customer shall be entitled to withdraw in the framework of the legal regulations.
7. Further claims arising from a delay in delivery are exclusively determined according to Law of these conditions.

## 5. TRANSFER OF RISK

1. Complaints can only be taken into account if submitted within 8 days of receipt of the goods. Delivered goods will only be accepted in return in their original packing. Illustrations and brochures etc. are not binding. Measurements and utilisation data are only to be regarded as approximate and are also not binding.
2. The risk shall pass to the customer, even in the event of delivery carriage-paid, as soon as the ready delivery is dispatched or collected. Unless the customer has given special dispatch instructions, delivery may be made at our discretion by the most suitable means. On request of the customer the delivery will be insured at his cost against breakage, transport and damage from fire or water.
3. In the event that dispatch or delivery is delayed at the request of the customer or for reasons for which he is responsible, the risk shall pass to the customer for the period of the delay, however at the request of the customer, we shall arrange the insurance cover he requires at his expense.

## 6. WARRANTY CLAIMS

Warranty claims shall be recognised, if the defect has been reported to us in writing within 12 months of the delivery date. To the exclusion of further claims – subject to law, we will provide a warranty as follows:

1. We shall have the option to either replace or to carry out repairs free of charge on all those parts which prove to be defective due to circumstances which occurred prior to the transfer of risk. The discovery of such defects must be reported to us immediately in writing. Replaced parts become our property.
2. If we have to supply according to drawings, specifications, samples etc. provided by the customer, then the customer carries the risk for the suitability for the intended purpose.

Decisive for the condition of the goods conforming to the agreement is the point in time of the transfer of risk according to section V.

3. If a final inspection of the goods has been agreed or an inspection of the first sample, then customer's complaints will not be recognised later concerning defects which the customer should have noticed at the final inspection or inspection of the first sample if it had been carried out with due care and attention.
4. We must be given an opportunity to confirm the defect the complaint is being made about. Rejected goods must be returned to us immediately on demand. We will bear the transport costs if the customer complaint is justified. If the customer does not comply with these obligations or makes changes to the rejected goods without our agreement, then he forfeits any claims under warranty of quality.
5. Only in urgent cases, in which operational security is endangered or to prevent a disproportionate amount of damage being incurred, does the customer have the right to remedy the defect or have it remedied by a third party and to demand compensation from us for expenses thus incurred, whereby we must be informed immediately
6. Of costs incurred due to the rectification of defects or the replacement delivery, providing the complaint proves to be justified, we will bear the costs for the replacement goods including transport and also reasonable costs for disassembly and assembly.
7. Within the framework of legal provisions, the customer has the right to withdraw from the contract if, taking the legal exceptions into consideration, we do not successfully make use of a reasonable period of time given to us for rectification of defects or a replacement delivery due to a redhibitory defect. If the defect is insignificant, then the customer only has the right to claim a reduction of the contractual price. In all other cases the right to a reduction of the agreed price is excluded.
8. No warranty will be given in the following cases in particular: Unsuitable or inappropriate use, faulty installation or start-up by the customer or a third party, natural wear and tear, incorrect or negligent treatment, maintenance not carried out correctly, unsuitable construction work, unsuitable foundation, chemical, electrochemical or electrical influences providing we are not liable for them.
9. If the customer or a third party reworks the goods incorrectly, then we are not liable for the consequences arising from this. The same applies to changes made to the delivery item without our prior agreement.
10. We only provide a warranty for accessories added on within the framework of the warranty provided by our supplier.

## 7. LIABILITY

1. If we are responsible for the customer not being able to use the delivery item as stipulated in the contract as a consequence of suggestions made and consultations carried out before or after the contract was concluded which were omitted or carried out incorrectly or through infringing upon other subsidiary obligations - in particular instructions for operating and maintaining the delivery item - then to the exclusion of further claims made by the customer, the stipulations in sections VI and VII.2 apply correspondingly.
2. For damages, which have not been incurred by the delivery item itself, we only accept liability - whatever legal reasons are given - in the case of
  - intent,
  - gross negligence by executive employees,
  - culpable injury of life, body, health,
  - malicious silence with regard to a defect or the non-existence of which had been guaranteed
  - defects of the delivery item for which liability must be accepted according to the German

Law on Product Liability for damages to persons or property with regards to privately used objects. In the case of culpable infringement of essential contractual obligations, we also accept liability for gross negligence of non-executive employees and in the case of slight negligence, in the latter case limited to reasonable, foreseeable damages typical to a contract. Any further claims shall be excluded.

## 8. STATUTORY LIMITATION

All claims made by the customer - for whatever legal reasons - are subject to a limitation period of 12 months. For wilful or fraudulent behaviour and for claims based on the Indian Law, the legal limitations apply. They shall also apply to defects in a building structure or for delivery items that were used in accordance with the normal use for a building structure and caused its defectiveness.

## 9. PLACE OF PERFORMANCE AND JURISDICTION

1. Place of fulfilment and exclusive place of jurisdiction for all claims arising out of this agreement, including proceedings related to bills of exchange, cheques /DD or documents, shall be Bangalore.
2. Indian law shall be applicable to matters arising out of this Agreement.

## 10. VALIDITY OF THE AGREEMENT

Should one or more of the provisions of this Agreement be or become invalid for any reason, the provisions should be interpreted to ensure that the commercial aim of the original, invalid provision is upheld. The validity of the remaining provisions shall remain unaffected.

## PRODUCT SELECTION GUIDE

### OXY-FUEL CUTTING SYSTEMS

The matrix below works as a basic guideline for the selection of suitable product combinations for flame cutting of carbon steel. The material thickness is the basic factor in determining the combination of cutting equipment. Where more than one variant is recommended they are listed in order of their power / performance, the most powerful listed last. In the case of special applications or atypical setups it is always recommended to consult with GCE experts.

Plate thickness	Nozzle	Torch	Checkvalve	Hose	Flashback Arrestors	Regulators
10 mm	AFN	ORBIT	G1/4" LH + RH G3/8" LH + RH	Diam. 6,3 mm	FR20 FR34 FR50	FIXICONTROL UNICONTROL MULTISTAGE
20 mm	ANM/ PNM	MK3				
30 mm	ANME / PNME	NM250				
50 mm	ANM / PNM ANME / PNME	MK3 NM250	G3/8" LH + RH	Diam. 8 mm	FR34 FR50	UNICONTROL MULTISTAGE
75 mm						
100 mm						
125 mm						
150 mm						
175 mm	ANM / PNM ANME / PNME	NM250	G3/8" LH + RH	Diam. 8 mm	FR34 FR50	UNICONTROL MULTISTAGE
200 mm						
225 mm						
250 mm						
275 mm						
300 mm	Consult with GCE	Consult with GCE		Diam. 10 mm	FR50 FR19N	CENTRAL GAS SUPPLY
400 mm						
500 mm						
600 mm						

#### 1. RECOMMENDED LIGHT DUTY CUTTING SYSTEM

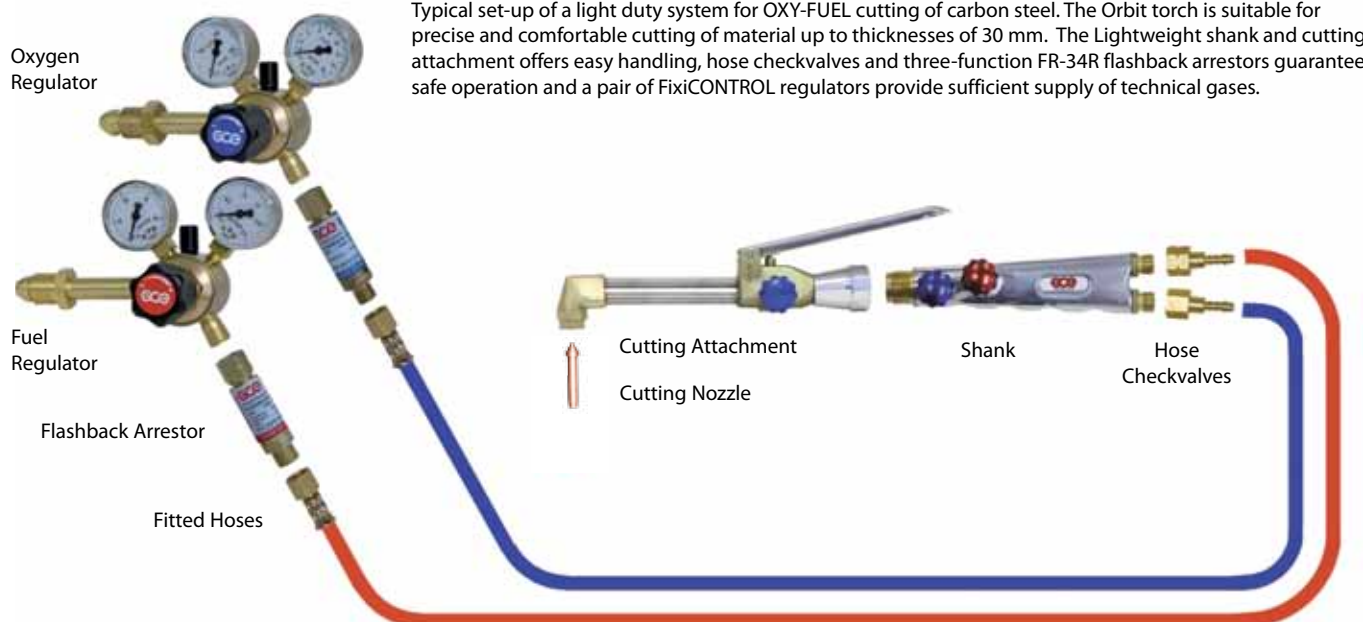

Plate thickness	Nozzle	Torch	Checkvalve	Hose	Flashback Arrestors	Regulators
1 - 3	0769416	0766229 - Shank ORBIT + 0766230 - Cutting attachment ORBIT	0764142 - BV12 HCV 1/4 x 6,3 RH	Hose 6,3 x 13,3	0764429 FR-34R OXY G3/8"	0871017 FIXICONTROL OXYGEN
3 - 6	0769285		+ 0764141 - BV12 HCV 1/4 x 6,3 LH		+ 0764428	+ 0871018
6 - 20	0769287				FR-34R FUEL G3/8" LH	FIXICONTROL ACETYLENE
20 - 30	0768825					

## 2. RECOMMENDED MEDIUM DUTY CUTTING SYSTEM



Medium duty cutting system based on the MK3 torch provides enough power for the cutting of 150 mm steel plates. Aluminum forged shank and cutting attachment with solid machined brass body, head and stainless steel tubes make the entire system robust and durable whilst still maintaining its weight reasonably low. The shank and cutting attachment are part of the complex MK3 system offering wide range of compatible products and accessories.

High-end Unicontrol regulators and sophisticated four-function FR50 flashback arrestors provide stable gas supply and allow later expansion of the system and potential use of even more powerful torches and nozzles.

Plate thickness	Nozzle ACE	Nozzle PROP	Torch	Checkvalve	Hose	Flahback Arrestor	Regulators
3 - 6	0768554	0768880	0766241 - MK3 Shank +	0764144 - BV12 G3/8" x 6,3 RH +	Hose 6,3 x 13,3	0764424 FR-50 OXY G3/8" RH +	0783976 UNICONTROL OXYGEN +
5 - 12	0768555	0768865					
10 - 75	0768556	0768879					
70 - 100	0768557	0768878	0766242 - MK3 Cutting Attachment	0764143 - BV12 G3/8" x 6,3 LH		0764425 FR-50 FUEL G3/8" LH	0783980 UNICONTROL ACETYLENE
90 - 150	0768558	0769481					

## 3. RECOMMENDED HEAVY DUTY CUTTING SYSTEM

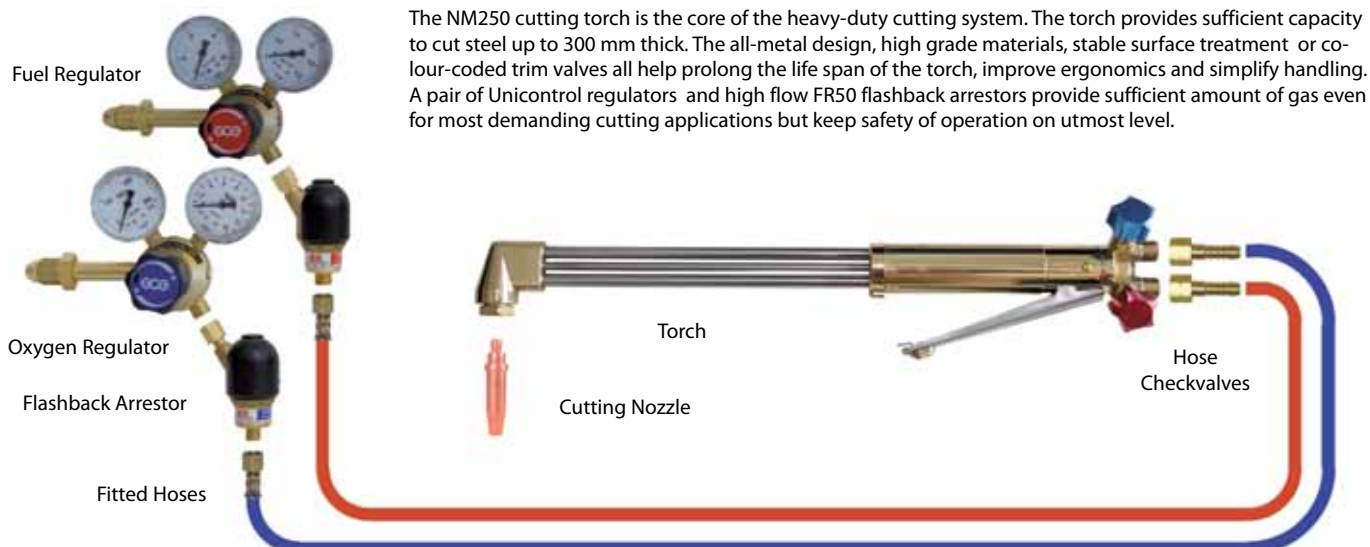

The NM250 cutting torch is the core of the heavy-duty cutting system. The torch provides sufficient capacity to cut steel up to 300 mm thick. The all-metal design, high grade materials, stable surface treatment or colour-coded trim valves all help prolong the life span of the torch, improve ergonomics and simplify handling. A pair of Unicontrol regulators and high flow FR50 flashback arrestors provide sufficient amount of gas even for most demanding cutting applications but keep safety of operation on utmost level.

Plate thickness	Nozzle ACE	Nozzle PROP	Torch	Checkvalve	Hose	Flahback Arrestor	Regulators
3 - 6	0768670	0769494	0766225 - NM250 Cutting Torch 490 mm or	07644146 - BV12 G3/8" x 8 RH +	Hose 8 x 15	0764424 FR-50 OXY G3/8" RH +	0783976 UNICONTROL OXYGEN +
5 - 12	0768635	0769495					
10 - 75	0768599	0769496					
70 - 100	0768636	0769497	0766226 - NM250 Cutting Torch 700 mm	0764145 - BV12 G3/8" x 8 LH		0764425 FR-50 FUEL G3/8" LH	0783980 UNICONTROL ACETYLENE
90 - 150	0768662	0769498					
140 - 200	0768598	0769499					
190 - 300	0769041	0769501					

## OXY-FUEL WELDING SYSTEMS

### 1. RECOMMENDED LIGHT DUTY WELDING SYSTEM

Oxygen  
Regulator

Fuel  
Regulator

Flashback Arrestor

Fitted Hoses

The Orbit welding set-up benefits from a lightweight aluminum shank and extremely precise copper welding tips. Its smaller dimensions and perfect balance make the Orbit set ideal for all applications where neat and accurate welding is required. Fixicontrol regulators recommended for this light-duty kit guarantee perfect pressure stability so important for accurate flame setting. Despite welding being a less risky operation than heavy duty cutting GCE still recommends protecting the system and more importantly the operator by the use of adequately selected flashback arrestors. A pair of three-function FR34 arrestors keep the cost of the system to a reasonable level without any compromising of safety.



Plate thickness	Welding tip	Torch	Checkvalve	Hose	Flashback Arrestors	Regulators
1 - 8 mm	0766232	0766229 - Shank ORBIT	0764142 - BV12 HCV 1/4 x 6,3 RH	Hose 6,3 x 13,3	0764429 FR-34R OXY G3/8"	0871017 FIXICONTROL OXYGEN
	-	+	+		+	+
	0766240	0766231 - MIXER ORBIT	0764141 - BV12 HCV 1/4 x 6,3 LH		0764428 FR-34R FUEL G3/8"LH	0871018 FIXICONTROL ACETYLENE

### 2. RECOMMENDED HEAVY DUTY WELDING SYSTEM

Fuel Regulator

Oxygen Regulator

Flashback Arrestor

Fitted Hoses

Our heavy duty welding system built around the robust MK3 shank presents a sturdy and reliable base for all general welding operations. On top of higher robustness and durability the major advantage of MK3 system is a much bigger potential for future expansion into cutting and heating applications. The Fixicontrol regulators and FR34 arrestors are still a perfectly safe choice even for heavy duty welding however if you plan to use the same gas source for oxy-fuel cutting then the more powerful Unicontrol regulators combined with FR50 flashback arrestors must be considered.

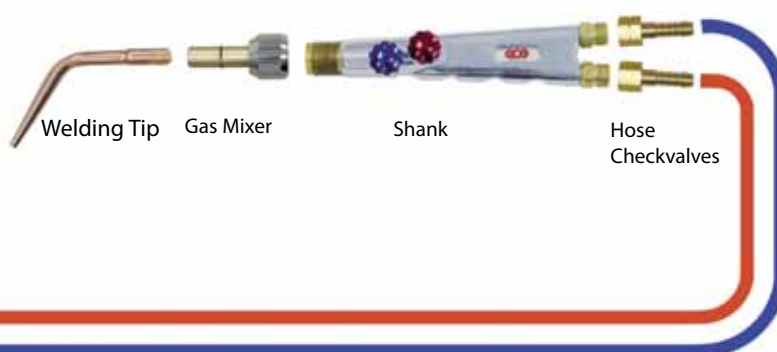

Plate thickness	Welding tip	Torch	Checkvalve	Hose	Flashback Arrestor	Regulators
1 - 8 mm	0766244	0766241 - Shank MK3	0764144 - BV12 G3/8" x 6,3 RH	Hose 6,3 x 13,3	0764429 FR-34R OXY G3/8"	0783976 UNICONTROL OXYGEN
	-	+	+		+	+
	0766252	0766243 - Mixer MK3	0764143 - BV12 G3/8" x 6,3 LH		0764428 FR-34R FUEL G3/8"LH	0871018 UNICONTROL ACETYLENE



## OXY-FUEL HEATING SYSTEMS

The precise selection of the correct heating torch is always entirely dependent on the application you need to solve. It is important to know if you plan on brazing, straightening, surface treatment or other thermal treatment. It is always necessary to know the temperature level you need to reach and the speed of preheating.

If required to straighten a welded construction then a torch with a very concentrated flame is needed.

If required for preheating of metal (casting or forging) a completely different torch must be used to heat up the bigger component's surface.

To keep all heating torches working properly it is necessary to use high flow FR-50 FBA with powerful Unicontrol regulators. 8 mm hoses are a key factor in delivering enough gases for reliable performance.

Even proper equipment cannot guarantee reliable function if gas supply is not strong enough.

### ACETYLENE TORCHES

Max. acetylene supply from a 50-liter bottle = approximately 1 m<sup>3</sup>/h.

Reliable function of these torches is guaranteed only with supply from an acetylene bundle!

### PROPANE TORCHES

Max. propane supply from a 33-kg bottle = approximately 1,6 m<sup>3</sup>/h.

Reliable function of these torches is guaranteed only with supply from a propane bundle or tank!

## 1. RECOMMENDED HEATING SYSTEM

GCE recommend the MK3-based heating system for heating, flame straightening, stress-relieving and other related flame applications. GCE offers a wide selection of specialized torches, burners and superheating heads compatible with standard MK3 shank and gas mixer. Despite propane often being the gas of choice the use of high capacity FR50 flashback arrestors is strongly recommended due to enormous gas consumption and high flow rates needed for heating operations. For the same reason the Unicontrol regulators are recommended offering very high flow capacity.



Nozzle	Torch	Checkvalve	Hose	Flashback Arrestors	Regulators
0769472	0766241 - MK3 Shank	07644146 - BV12	Hose 8 x 15	0764424	0783976
-	+ 0766253 - MK3 Mixer	+ G3/8" x 8 RH		FR-50 OXY G3/8" RH	UNICONTROL OXYGEN
0769476	+ 0766254 Neck Tube	0764145 - BV12		+ 0764425	+ 0783979
		G3/8" x 8 LH		FR-50 FUEL G3/8" LH	UNICONTROL LPG



## PRESSURE REGULATORS

## PRESSURE REGULATORS

*A Pressure Regulator is a device for regulating a generally variable inlet pressure to an as constant as possible outlet pressure.  
(EN ISO 2503)*

By name and definition, a pressure regulator is simply a kind of valve designed to regulate and stabilize system pressure downstream of its placement. The gas cylinder content is consumed stepwise during the operation and thus the pressure upstream of regulator varies from full cylinder pressure to values close to zero. The task of the pressure regulator is to cope with such variation and maintain outlet parameters as stable as possible.

### REGULATOR PRINCIPLE

A pressure regulator maintains downstream pressure by automatically modulating the level of the regulator heart valve opening and gas stream throttling.

By changing the area of opening as upstream pressures and downstream flow-rate vary, pressure drop through the heart valve changes proportionally to maintain the downstream pressure at a relative constant level and relatively independent from remaining cylinder content and - to some extent - independent to gas amount consumed.

Heart-valve opening or closing is driven and actuated by forces balance on regulator diaphragm. Ideally all forces caused by inner pressure conditions and forces generated by spring compression become perfectly balanced and the heart valve seat allows just the requested quantity of gas to expand into the low pressure chamber causing a steady, constant pressure gas stream.

In reality all conditions fluctuate and the heart-valve spindle constantly moves up or down to reflect changing conditions and regulate the opening appropriately. For that reason the proper design of diaphragm, right choice of heart-valve geometry and high-grade materials are key in regulator functionality and reliability. GCE utilize its more than 70 years of experience in regulator business to optimize product design and choose optimal technical solutions.

### PRODUCT SELECTION

To ensure a suitable level of accuracy in pressure maintenance and provide demanded gas flow-rate there are various models of pressure regulators available to meet specific flow and pressure requirements. To ensure the regulator functions correctly and thus a steady and sufficient gas supply, the user should always observe and consider the operating parameters before purchase of product. Your basic selection criteria should be at least the following:

#### GAS MEDIA

The intended working gas selection affects not only connection style but even inner design of the regulator and material compatibility of product with selected media. Never use regulators with other gases than specified by product marking even if inlet connection would allow. Such misuse could result in product damage and in potential health and safety hazards.

#### GAS PRESSURES

Consider the pressure range available on cylinder side and mainly the pressure requested on regulator output. Standard cutting, welding or heating operations can be served by FIXI\UNI\S2+ regulator series but even for special high-pressure applications the Jet-CONTROL 600 is available. Due to safety reasons all GCE regulators have maximum outlet pressure restricted close to nominal value stated in catalogue so pay attention for the right selection.

#### GAS FLOW

Not only gas pressure but also expected gas amount is equally important when selecting the correct regulator. Smaller FIXICON-TROL regulators provide enough gas for basic cutting and welding but for heavy-duty applications higher product lines must be used. For industrial application where the supply of extreme gas volume is needed the special CR60 product line is recommended. Similarly the capacity of gas source must be thoroughly considered too.

#### PRESSURE STABILITY

The pressure stability of the regulator is mostly affected by product size and design. Larger diameter of diaphragm dramatically improve stability, that is why UNI-CONTROL offers better parameters than smaller FIXICONTROL, but in many specific cases only S2+ MULTISTAGE regulator can provide ultimate stable pressure supply. If in doubt consult your GCE experts for the best selection.

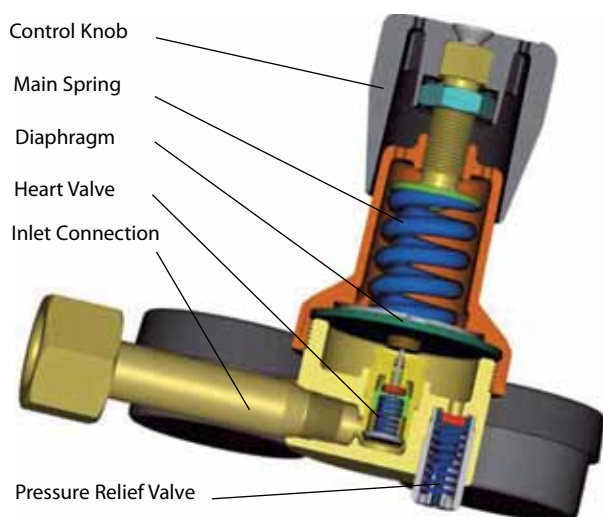

### SAFETY

Despite GCE designers and engineers paying utmost attention to pressure regulator safety there is still big responsibility laid on the end user. Pressure regulators are devices dealing with high gas pressures and - especially in cutting and welding applications - dealing with gases which can be potentially dangerous. Any contamination of oxygen washed surfaces by hydrocarbons (oil, grease, organic substances etc.) can lead to fire or explosion so cleanliness is of paramount importance for maintaining safe working conditions. Mechanical damage of connection components can result in leakage or release of broken particles and consequential damage of system. Potential leakage of flammable gases, especially if leaking gas accumulates, sooner or later results in ignition and fire. High attention must be paid to perfect condition of regulator safety valves. GCE regulators are robust and durable devices but appropriate handling, maintenance and care are necessary for their safe and reliable operation. Read and follow all recommendations mentioned in Instruction for Use provided with the product.

## UNICONTROL - SINGLESTAGE CYLINDER REGULATORS

UniCONTROLS are pressure regulators fully conforming to all paragraphs of International Standard ISO2503. The main focus during product design and manufacture was on providing excellent performance, robustness and durability and guaranteeing its uncompromised safety. The UniCONTROL regulators use a filter protected fully encapsulated heart valve, well proven over several generations of GCE regulators. The body is made of solid forged, high quality brass, polished and chemically stabilized. The zinc die-cast bonnet is protected by a double layer powder painting to guarantee corrosion resistance even in very aggressive environments. For operational safety the integrated Pressure Relief Valve, located on the rear of the body is designed to prevent end users from changing the factory setting.

These regulators are independently type-tested and certified by BAM Berlin (The German State Testing Institute) to work safely with up to 200 bar inlet pressure.



### TECHNICAL DATA

Body	Forged Brass, chemically stabilized (acid bright dipped)
Bonnet	Die-cast Zinc alloy, chemically stabilized and powder painted
Diaphragm	Diam. 55 mm fabric-reinforced EPDM rubber
Heart Valve	Encapsulated unit, brass body sealed by PA or high-grade chloroprene rubber
Pressure Gauges	Non-bulkhead 63mm gauges, class 2,5%, scale calibrated in Bar
Inlet Stem & Nut	Brass, geometry complying with BS-341 standard
Safety Valve	Non-adjustable, plastic housing
Control elements	Ergonomic PA control knob, captive pressure adjusting screw

### DIMENSIONS SCHEME

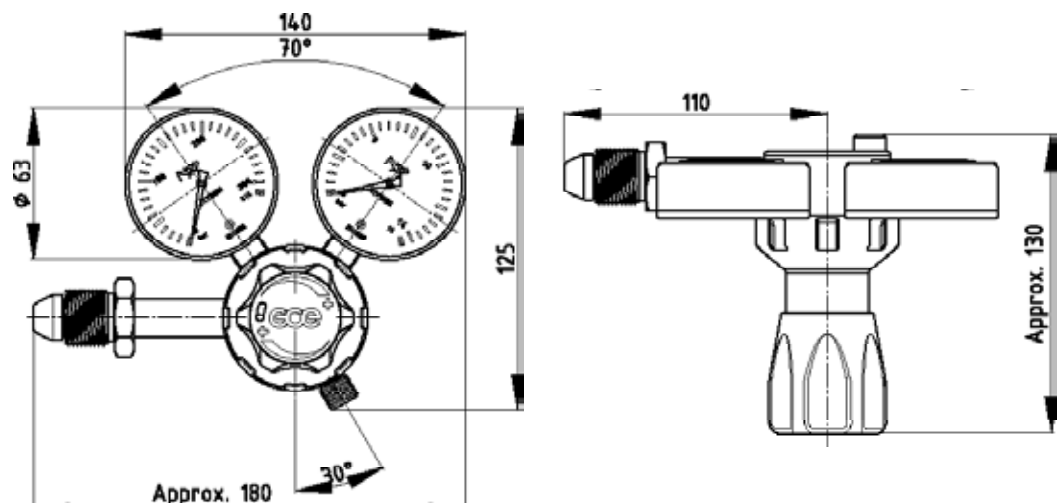



### PRODUCT FEATURES



### REGULATOR PARAMETERS

#### OXYGEN

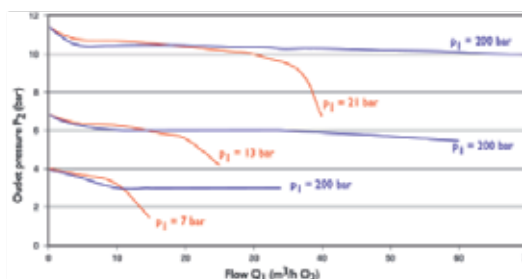

#### ACETYLENE

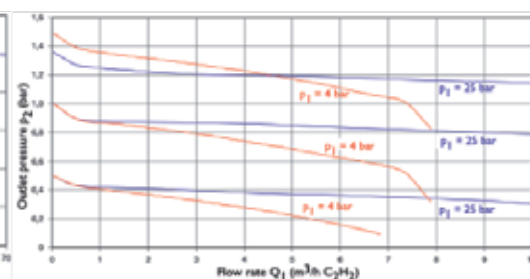

The capacity graphs show the outlet pressure as a function of the flowrate at different inlet pressures.

### PRODUCT VARIANTS



Art. Nr.	Gas	Max inlet pressure	Outlet pressure	Nominal flowrate	ISO 2503 class	Inlet connection	Outlet connection	Pressure/flow indication	Approx. weight
0783976	OXYGEN	200 bar**	0-10 bar	30 $m^3/h$	O3	G 5/8" RH M*	G 3/8" RH	2 gauges (63 mm)	1.45 kg
0783977	OXYGEN	200 bar**	0-20 bar	50 $m^3/h$	O5	G 5/8" RH M*	G 3/8" RH	2 gauges (63 mm)	1.45 kg
0783978	LPG	20 bar	0-1.5 bar	1 $m^3/h$	P0	0.860x1/14" LH	G 3/8" LH	2 gauges (63 mm)	1.35 kg
0783979	LPG	20 bar	0-4 bar	5 $m^3/h$	P1	0.860x1/14" LH	G 3/8" LH	2 gauges (63 mm)	1.35 kg
0783980	ACETYLENE	20 bar	0-1.5 bar	5 $m^3/h$	A2	G 5/8" M* LH	G 3/8" LH	2 gauges (63 mm)	1.45 kg
0783981	NEUTRAL (Ar/N/He)	200 bar**	0-10 bar	30 $m^3/h$	N3	G 5/8" RH M*	G 3/8" RH	2 gauges (63 mm)	1.45 kg
0783982	NEUTRAL (Ar/N/He)	200 bar**	0-20 bar	50 $m^3/h$	N5	G 5/8" RH M*	G 3/8" RH	2 gauges (63 mm)	1.45 kg
0783983	CO <sub>2</sub>	200 bar**	0-10 bar	30 $m^3/h$	N	0.860x1/14" F*	G 3/8" RH	2 gauges (63 mm)	1.45 kg
0789384	ARGON flow gauge	200 bar**	N/A	3-30 l/min full scale	N10	G 5/8" RH M*	G 3/8" RH	2 gauges (63 mm)	1.45 kg
0789385	CO <sub>2</sub> flow gauge	200 bar**	N/A	3-30 l/min full scale	N10	0.860x1/14"	G 3/8" RH	2 gauges (63 mm)	1.45 kg
0783986	ARGON - Tube flowmeter	200 bar**	N/A	3-30 l/min	N10	G 5/8" RH M*	G 3/8" RH	1 gauge + flowmeter	1.65 kg
0783987	CO <sub>2</sub> - Tube flowmeter	200 bar**	N/A	3-30 l/min	N10	0.860x1/14" F*	G 3/8" RH	1 gauge + flowmeter	1.65 kg
0783988	HYDROGEN	200 bar**	0-10 bar	30 $m^3/h$	H3	G 5/8" M* LH	G 3/8" LH	2 gauges (63 mm)	1.42 kg

\* M-male, F-female

\*\* The 230 bar inlet pressure may be used instead of 200 bar, no risk of damage.

\*\* 300 bar inlet pressure products available on request.

## FIXICONTROL - MEDIUM DUTY SINGLESTAGE CYLINDER REGULATORS

As with all other GCE regulators, the medium duty FixiCONTROL fully conforms with all paragraphs of The International Standard ISO2503. FixiCONTROL regulators are the optimal solution for customers working with mid-range oxy-fuel cutting & welding equipment (cutting steel thickness up to 200 mm ) or for customers who are using a shielding gas supply for less demanding arc-welding applications.

These regulators have both body and bonnet made of high-quality forged + chemically stabilized brass. Both inlet and outlet pressure / flow are measured and indicated by two 50mm pressure gauges. The regulator itself and all downstream devices are protected by an integrated non-adjustable Pressure Relieve Valve.

These regulators are independently type-tested and certified by BAM Berlin (The German State Testing Institute) to work safely with up to 200 bar inlet pressure



### TECHNICAL DATA

Body	Forged Brass, chemically stabilized
Bonnet	Forged Brass, chemically stabilized
Diaphragm	Diam. 43 mm, fabric-reinforced EPDM rubber
Heart Valve	Encapsulated unit, brass body sealed by PA or high-grade chloroprene rubber
Pressure Gauges	Non-bulkhead 50mm gauges, class 2,5%, scale calibrated in Bar
Inlet Stem & Nut	Brass, geometry complying with BS-341 standard
Safety Valve:	Non-adjustable, plastic housing
Control elements	Ergonomic PA control knob, captive pressure adjusting screw

### DIMENSIONS SCHEME

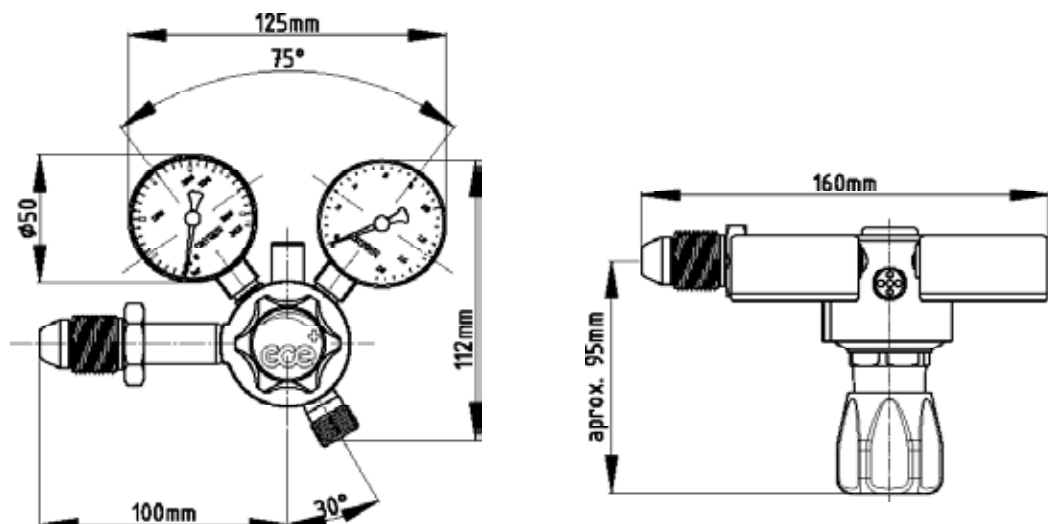

## PRODUCT FEATURES

Inlet Connections exactly complying with BS-341 Standards

Non-detachable Ergonomic Plastic control knob

Max. Outlet pressure locked for operational safety

Colour Coded Control Elements



Precise & Easy Legible 50 mm Gauges

Safety valve located on top side of body – not adjustable for operational safety

Technical Data permanently marked on body

Body and Bonnet forged from high-quality Brass

## REGULATOR PARAMETERS

### OXYGEN

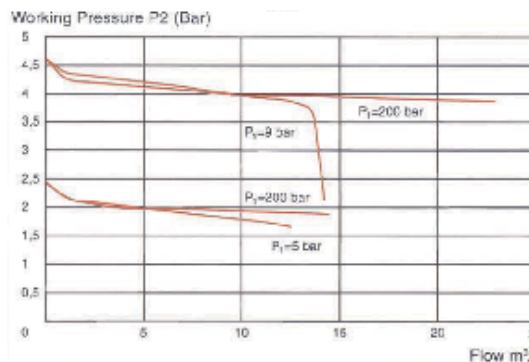

### ACETYLENE

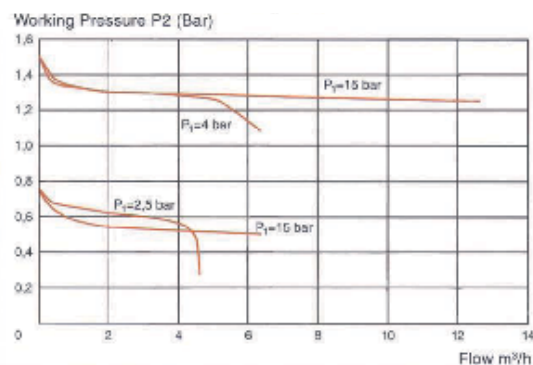

The capacity graphs show the outlet pressure as a function of the flow rate at different inlet pressures.

## PRODUCT VARIANTS



Art. Nr.	Gas	Max inlet pressure	Outlet pressure	Nominal flowrate	ISO 2503 class	Inlet connection	Outlet connection	Pressure/flow indication	Approx. weight
0871016	LPG	20 bar	0-1.5 bar	1 m³/h	P0	0.860x1/14" LH	G 3/8" LH	2 gauges (50 mm)	1.15 kg
0871017	OXYGEN	200 bar**	0-10 bar	30 m³/h	O3	G 5/8" RH M*	G 3/8" RH	2 gauges (50 mm)	1.15 kg
0871018	ACETYLENE	20 bar	0-1.5 bar	5 m³/h	A2	G 5/8" M* LH	G 3/8" LH	2 gauges (50 mm)	1.15 kg
0871019	NEUTRAL (Ar/N/He)	200 bar**	0-10 bar	30 m³/h	N3	G 5/8" RH M*	G 3/8" RH	2 gauges (50 mm)	1.15 kg
0871020	CO <sub>2</sub>	200 bar**	0-10 bar	30 m³/h	N	0.860x1/14" F*	G 3/8" RH	2 gauges (50 mm)	1.15 kg
0871021	ARGON flow gauge	200 bar**	N/A	3-30 l/min full scale	N10	G 5/8" RH M*	G 3/8" RH	2 gauges (50 mm)	1.15 kg
0871022	CO <sub>2</sub> flow gauge	200 bar**	N/A	3-30 l/min full scale	N10	0.860x1/14" F*	G 3/8" RH	2 gauges (50 mm)	1.15 kg
0871023	ARGON flow	200 bar**	N/A	3-30 l/min	N10	G 5/8" RH M*	G 3/8" RH	1 gauge + flowmeter	1.45 kg
0871024	CO <sub>2</sub> flow	200 bar**	N/A	3-30 l/min	N10	0.860x1/14" F*	G 3/8" RH	1 gauge + flowmeter	1.45 kg
0871025	HYDROGEN	200 bar**	0-10 bar	30 m³/h	H3	G 5/8" M* LH	G 3/8" LH	2 gauges (50 mm)	1.15 kg

\* M-male, F-female

\*\* The 230 bar inlet pressure may be used instead of 200 bar, no risk of damage.

\*\* 300 bar inlet pressure products available on request.

## S2+ MULTISTAGE - HEAVY DUTY DOUBLESTAGE CYLINDER REGULATORS

GCE multi-stage regulators are designed to provide accurate, fluctuation free delivery for precision applications such as machine cutting or laboratory use. The first stage reduces the inlet pressure by over 90% and the large second stage diaphragm ensures accurate delivery pressure. GCE multistage regulators are precision built to latest EN ISO 2503 and EN ISO 7291 standards to provide maximum accuracy and safety.

These regulators have the additional feature of being able to pipe away gases from the relief valve port, and comply with the stringent requirements of EN ISO 7291 even for strict manifold application.



### TECHNICAL DATA

Body	Forged Brass, chemically stabilized and gold powder-painted
First stage Bonnet	Forged Brass, chemically stabilized and powder painted
Second stage Bonnet	Die-cast Zinc alloy, chemically stabilized and powder painted
First stage Diaphragm	Diam. 40 mm, pre-shaped stainless steel
Second stage Diaphragm	Diam. 82 mm EPDM fabric-reinforced rubber
Heart Valves	Brass body sealed by PA (first stage) or high-grade chloroprene rubber (second stage)
Pressure Gauges	Safe design, bulkhead 50mm gauges, dual scales, accuracy class 2,5%
Inlet Stem & Nut	High-tensile brass, geometry complying with BS-341 standard
Safety Valves	On both regulator stages, non-adjustable,
Control elements	Plastic control knob + captive pressure adjusting screw
Setting	Ergonomic PA control knob, adjustable limitation of P2 max

### DIMENSIONS SCHEME

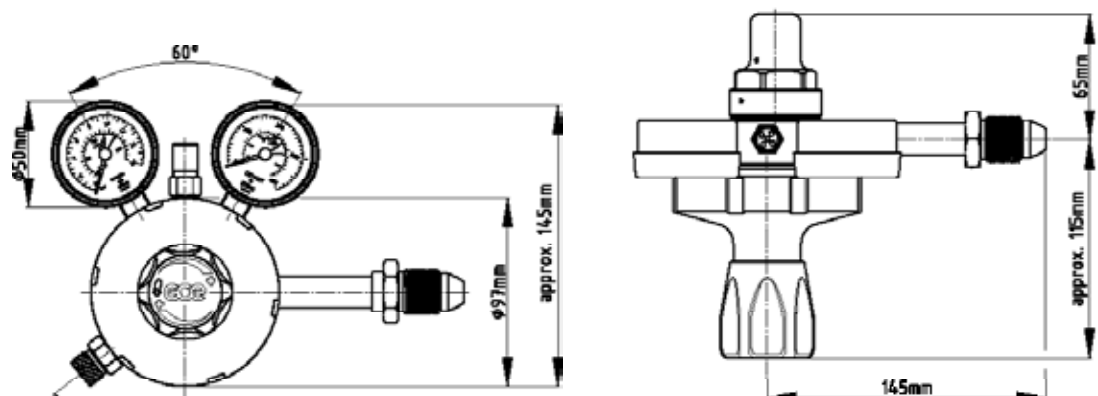



### PRODUCT FEATURES

Top-safe & Accurate Bulkhead 50mm Gauges

Body and 1st. Bonnet forged from high-quality Brass

Technical Data permanently marked on body

Powder-painted surface for high corrosion resistance

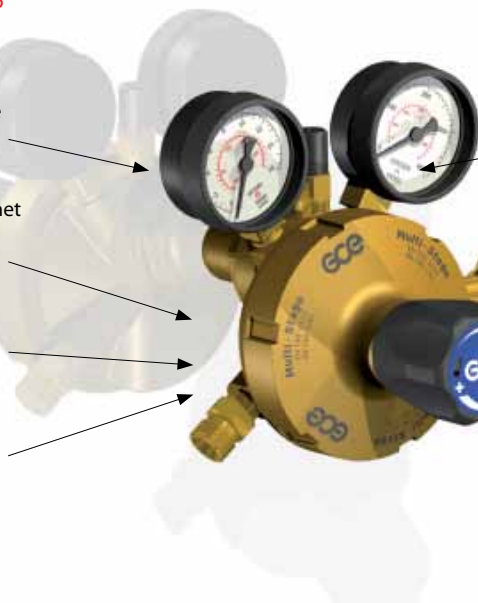

Non-adjustable safety valve located on top side of body

Inlet Connections exactly complying with BS-341 Standards

Max. Outlet pressure locked for operational safety

Non-detachable Ergonomic Plastic control knob

### REGULATOR PARAMETERS

OXYGEN

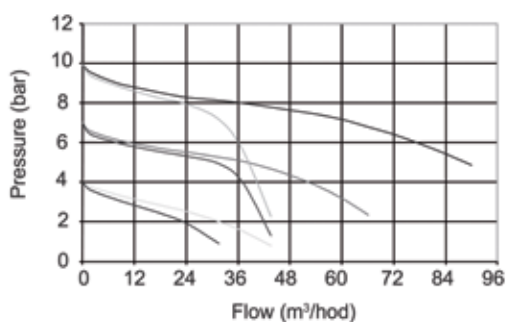

ACETYLENE

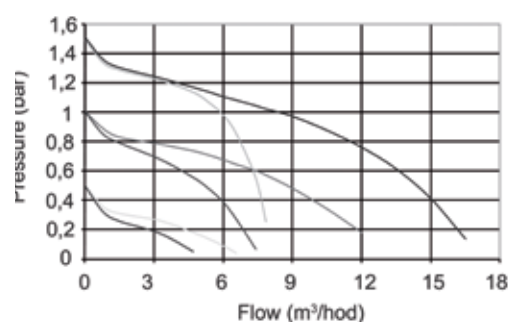

### PRODUCT VARIANTS



Art. Nr.	Gas	Max inlet pressure	Outlet pressure	Nominal flowrate	ISO 2503 class	Inlet connection	Outlet connection	Pressure/flow indication	Approx. weight
0772028	OXYGEN	230 bar	0-10 bar	30 m <sup>3</sup> /h	O3	G5/8" RH M*	G 3/8" RH	2 gauges (63 mm)	2.55 kg
0772029	ACETYLENE	25 bar	0-1.5 bar	5 m <sup>3</sup> /h	A2	G5/8" M* LH	G 3/8" LH	2 gauges (63 mm)	2.55 kg
0772030	NEUTRAL (Ar/N/He)	230 bar	0-10 bar	30 m <sup>3</sup> /h	N3	G5/8" RH M*	G 3/8" RH	2 gauges (63 mm)	2.55 kg
0772031	CO <sub>2</sub>	230 bar	0-10 bar	30 m <sup>3</sup> /h	N	0.860x1/14" F*	G 3/8" RH	2 gauges (63 mm)	2.55 kg
0772032	ARGON flow gauge	230 bar	N/A	3-30 l/min full scale	N10	G5/8" RH M*	G 3/8" RH	2 gauges (63 mm)	2.55 kg
0772033	CO <sub>2</sub> flow gauge	230 bar	N/A	3-30 l/min full scale	N10	0.860x1/14" F*	G 3/8" RH	2 gauges (63 mm)	2.55 kg
0772034	HYDROGEN	230 bar	0-10 bar	30 m <sup>3</sup> /h	H3	G5/8" M* LH	G 3/8" LH	2 gauges (63 mm)	2.55 kg

\* M-male, F-female.

\*\* 300 bar inlet pressure products available on request.

## JETCONTROL 600 - HIGH PRESSURE CYLINDER REGULATORS

JETCONTROL 600 are single stage, two gauge cylinder regulators extensively used in oil refineries, laboratories or industrial processes requiring precise and stable delivery of high pressure industrial gasses. Regulators are primarily designed, tested and manufactured to operate on max. inlet pressure up to 300 Bar and providing pressure outlet up to 206 Bar. Its robust design, top-grade materials and strictly controlled manufacturing and testing procedures guarantee high operational safety even if working with small-molecular gases (like helium or hydrogen) at very high pressures. Key components manufactured from high-tensile brass, use of extra-safe and accurate bulkhead gauges, double-layer high-grade stainless-steel diaphragms and efficient metal filters help to prolong regulator service life and ensure trouble-free operation of JETCONTROL 600 regulators.



### TECHNICAL DATA

Body	High-tensile brass, chemically stabilized and transparent powder-painted
Bonnet	Brass, chemically stabilized and transparent powder-painted
Diaphragm	Two-layer, diam. 40 mm, pre-shaped stainless steel
Heart Valves	Brass body sealed by high-grade PA
Pressure Gauges	Safe design, bulkhead 50mm gauges, scale in Bar, accuracy class 2,5%
Inlet Stem & Nut	High-tensile brass, geometry complying with BS-341 standard
Safety Valve	Not-present, must be an independent part of downstream gas line
Pressure Setting	Stainless steel T-bar, brass pressure adjusting screw in bronze bush

### DIMENSIONS SCHEME

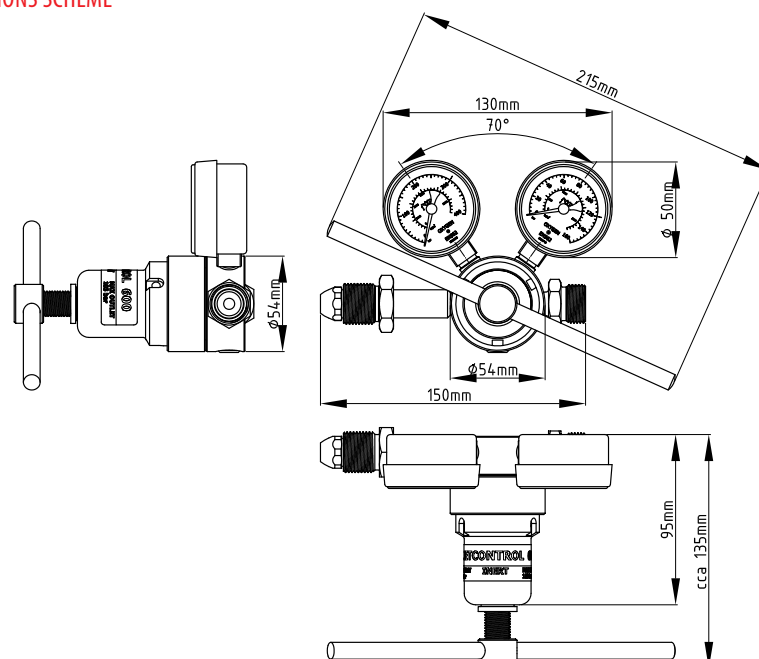

### PRODUCT FEATURES



### REGULATOR PARAMETERS

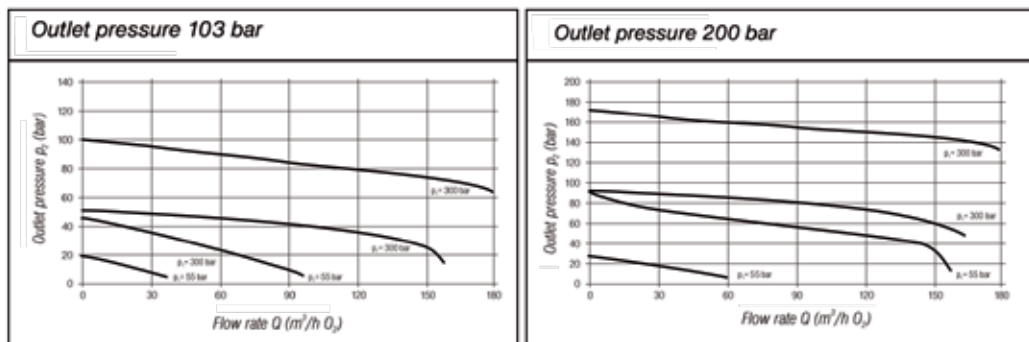

### PRODUCT VARIANTS



Art. Nr.	Gas	Inlet pressure	Outlet pressure	Flowrate	Inlet connection	Outlet connection	Approx. weight
0766022	OXYGEN	230 bar	206 bar	180 m <sup>3</sup> /h	G 5/8" RH Male (BSP 341 #3) - side	0.860x1/14" + 6mm nipple	1.75 kg
0766024	OXYGEN	230 bar	100 bar	150 m <sup>3</sup> /h	G 5/8" RH Male (BSP 341 #3) - side	0.860x1/14" + 6mm nipple	1.75 kg
0766026	NEUTRAL (Ar/N/He)	230 bar	206 bar	180 m <sup>3</sup> /h	G 5/8" RH Male (BSP 341 #3) - side	0.860x1/14" + 6mm nipple	1.75 kg
0766028	NEUTRAL (Ar/N/He)	230 bar	100 bar	150 m <sup>3</sup> /h	G 5/8" RH Male (BSP 341 #3) - side	0.860x1/14" + 6mm nipple	1.75 kg
0766030	HYDROGEN	230 bar	206 bar	180 m <sup>3</sup> /h	G 5/8" Male LH (BSP 341 #4) - side	0.860x1/14" + 6mm nipple	1.75 kg
0766032	HYDROGEN	230 bar	100 bar	150 m <sup>3</sup> /h	G 5/8" Male LH (BSP 341 #4) - side	0.860x1/14" + 6mm nipple	1.75 kg
0762867	OXYGEN	230 bar	100 bar	150 m <sup>3</sup> /h	G 5/8" Male LH (BSP 341 #4) - bottom	0.860x1/14" + 6mm nipple	1.65 kg
0762511	OXYGEN	230 bar	170 bar	160 m <sup>3</sup> /h	G 5/8" Male LH (BSP 341 #4) - bottom	0.860x1/14" + 6mm nipple	1.65 kg
0762865	NEUTRAL (Ar/N/He)	230 bar	100 bar	150 m <sup>3</sup> /h	G 5/8" Male LH (BSP 341 #4) - bottom	0.860x1/14" + 6mm nipple	1.65 kg
0762866	NEUTRAL (Ar/N/He)	230 bar	170 bar	160 m <sup>3</sup> /h	G 5/8" Male LH (BSP 341 #4) - bottom	0.860x1/14" + 6mm nipple	1.65 kg

## CR60 - HIGH FLOW CYLINDER REGULATORS

The high-flow CR60 pressure regulators have considerably higher capacity than other common cylinder regulators and are designed for use when particularly large flows of gas are required. The large diaphragm, physically separated from the main gas stream provides the regulator with its outstanding performance, excellent parameters and high freeze resistance.

The valve seats are made of material specially selected for use with all common industrial gases. Robust brass body and bonnet combined with stainless-steel inlet stem predetermines CR60 for heavy duty applications even in harsh industrial environments. All CR60 regulators are equipped with independently set and tested safety valves and each piece of CR60 has been individually tested before delivery.



### TECHNICAL DATA

Body	Forged brass, chemically stabilized and electro-polished
Bonnet	Forged brass, chemically stabilized and electro-polished
Diaphragm	Diam. 78 mm, two-layer, fabric reinforced EPDM rubber
Heart Valves	Stainless steel body sealed by high-grade PTFE
Pressure Gauges	Safe design, bulkhead 50mm gauges, scale in Bar, accuracy class 2,5%
Inlet Stem & Nut	High-tensile brass, geometry complying with BS-341 standard
Safety Valve	Integrated on top side of regulator, independently set and tested
Pressure Setting	Stainless steel T-bar, stainless steel pressure adjusting screw with ball-bearing

### DIMENSIONS SCHEME

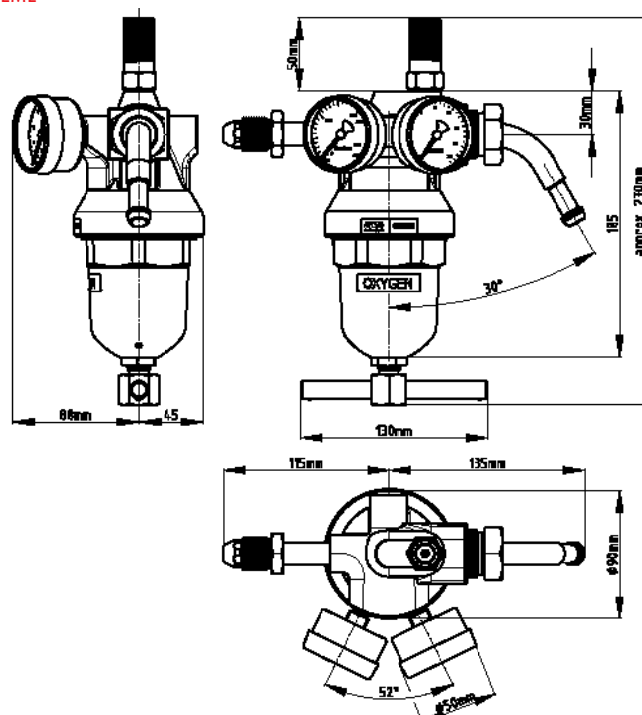



### PRODUCT FEATURES

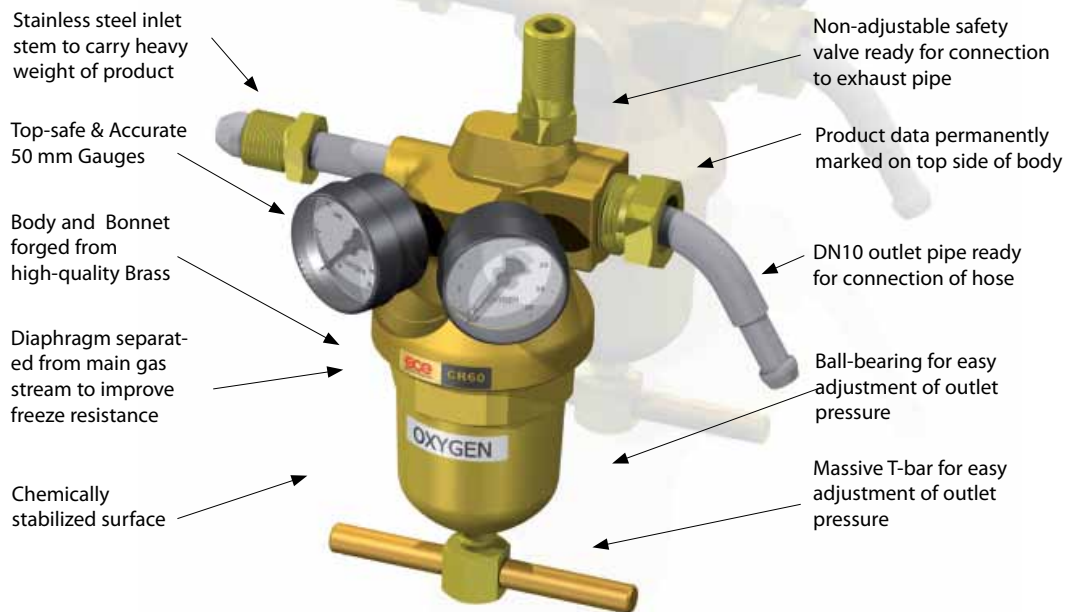

### REGULATOR PARAMETERS

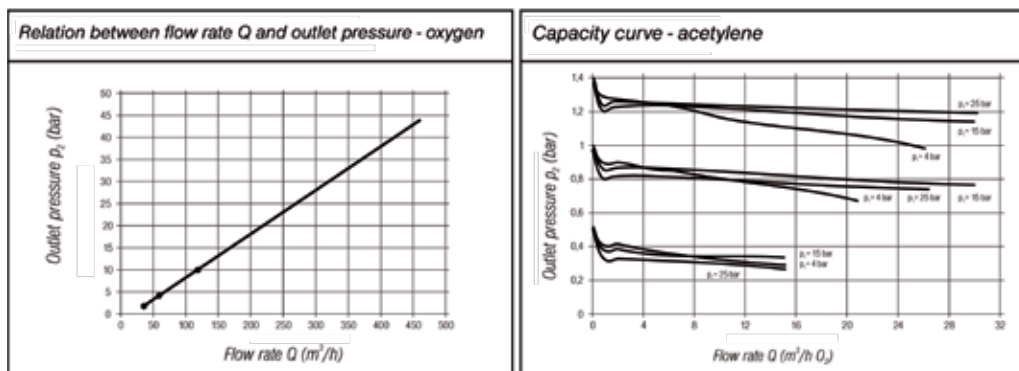

### PRODUCT VARIANTS



Art. Nr.	Gas	Inlet pressure	Outlet pressure	Flowrate	Inlet connection	Outlet connection	Pressure/flow indication	Approx. weight
0762918	OXYGEN	200 bar	15 bar	180 m <sup>3</sup> /h	G 5/8" RH (M)	G 1" RH + 8mm hose adaptor	2 gauges (50 mm)	4.75 kg
0762920	OXYGEN	200 bar	50 bar	580 m <sup>3</sup> /h	G 5/8" RH (M)	G 1" RH + 8mm hose adaptor	2 gauges (50 mm)	4.75 kg
0762922	NEUTRAL (Ar/N/He)	200 bar	15 bar	180 m <sup>3</sup> /h	G 5/8" RH (M)	G 1" RH + 8mm hose adaptor	2 gauges (50 mm)	4.75 kg
0762924	NEUTRAL (Ar/N/He)	200 bar	50 bar	580 m <sup>3</sup> /h	G 5/8" RH (M)	G 1" RH + 8mm hose adaptor	2 gauges (50 mm)	4.75 kg
0762926	HYDROGEN	200 bar	15 bar	180 m <sup>3</sup> /h	G 5/8" LH (M)	G 1" RH + 8mm hose adaptor	2 gauges (50 mm)	4.75 kg
0762928	HYDROGEN	200 bar	50 bar	580 m <sup>3</sup> /h	G 5/8" LH (M)	G 1" RH + 8mm hose adaptor	2 gauges (50 mm)	4.75 kg

\* M-male, F-female

\*\* The 230 bar inlet pressure may be used instead of 200 bar, no risk of damage.

## SPECIAL PURPOSE REGULATORS

### "M600" SERIES

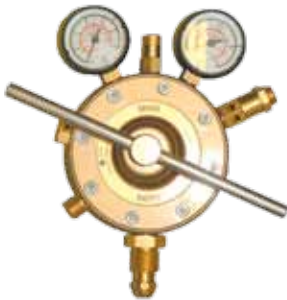

"M600" series – improved delivery pressure control is achieved from two stage regulation. Typical applications are those left unattended for periods of time such as cable pressurisation, chemical and laboratory. Range up to 41 bar delivery pressure.

Art. Nr.	Type	Gas	Entry	Inlet (bar)	Outlet (bar)	Flow m <sup>3</sup> /h
0762398	M 600	CO <sub>2</sub>	side	200	41	80
0762397	M 600	Flammable	bottom	300	41	108
0762396	M 600	Inert	bottom	300	41	108
0762377	M 600	Inert	side	300	41	108
0762399	M 600	Oxygen	bottom	230	41	100

### "OR14" SERIES



"OR14" series – offering some of the highest flows in the GCE range through the use of a special monel tied valve, these are intended for cylinder and pipeline applications. The G5/8 inlet adaptor can be removed to reveal a 1" BSP flat seat female fitting. Range up to 14 bar delivery pressure.

Art. Nr.	Type	Gas	Entry	Inlet (bar)	Outlet (bar)	Flow m <sup>3</sup> /h
0783595	HR 14	Hydrogen	rear	230	14	450
0783594	OR 14	Oxygen	rear	230	14	120

### "S151" SERIES



"S151" series – this pipeline regulator is ideal for tank systems, rear entry to suit panel or line mounting. The large outlet configuration is necessary to give high flow from a relatively low inlet pressure source. Max inlet 24 bar and delivery up to 10 bar.

Art. Nr.	Type	Gas	Inlet thread	Outlet thread	Entry	Inlet (bar)	Outlet (bar)
0772037	S 151	Oxygen	G1"	G3/4"	rear	24	10





## FLASHBACK ARRESTORS

## SAFETY EQUIPMENT

If using high quality equipment kept in good condition and if such equipment is used properly maintaining all health and safety rules, oxy-fuel cutting and heating equipment is safe to handle. There is no substitute for proper training, safety procedures and adequate caution among those that operate oxy-fuel equipment. The right torch, nozzle and a stable source of gas as well as their professional handling is essential but still may not be sufficient. Daily practice shows that Backfire and Flashbacks not only may happen but happen quite frequently. Extra hardware in the form of reliably working flashback arrestors provides an additional safety barrier protecting the cutting/welding operator and surrounding property against health and safety risks and material damages.

### NATURE OF OXY-FUEL RISKS

In the course of proper operation the highly flammable mixture of gases is precisely mixed in the injector, mixer or directly in the cutting nozzle and then ignited and fully combusted right and only at the cutting / welding nozzle orifice. In reality the equipment may get damaged or worn, the gas supply pressure unstable or skills and concentration of the operator not reach necessary levels. Any of these reasons and several others may initiate a chain of events resulting in an accident. The most common mishaps are as follows:

#### BACKFLOWING

Backflow is a dangerous situation whereby oxygen is pushed into the flammable gas hose (or vice versa) creating a highly flammable / explosive gas mixture inside the flexible hoses. A damaged injector or mixer or – more often - clogged or blocked welding tip or damaged cutting nozzle can also cause a change of inner pressure conditions in the system resulting in backflow. Another case is where the reverse flow of a gas occurs when one cylinder runs out during operation, creating an imbalance of pressure in the system. The non-return valve units – both in check valves and/or flashback arrestors are the only devices able to minimize this serious risk.

#### FLASHBACK

A flashback is a momentary or sustained retrogression of the flame upstream of the mixer, usually in the torch or hoses. This is a potentially dangerous situation, particularly if the flame reaches the hoses, where an explosion will occur, causing a rupture or separation of the hose.

#### SUSTAINED BACKFIRE

Sustained backfire is the continuous burning of the flame back inside the torch, usually at the mixer or injector. Flames can also travel further upstream and in extreme cases can reach the regulator and gas cylinders. Sustained backfires are often accompanied by a hissing or squealing sound and/or a smoky, sharp-pointed flame. The user should immediately close all torch valves to avoid damage or injury. If a sustained backfire continues to burn without closing torch valves, severe damage to the torch, as well as an increased risk of fire, would result.

### FLASHBACK ARRESTORS

Flashback arrestors (FBAs) are common safety devices that stop or impede the progress of a flame upstream of the insertion point, avoiding back flow and build up of explosive mixtures inside of hoses and can protect the system in case of fire and stop pressure wave in the gas lines. Different FBA provides a different combination of basic safety features:

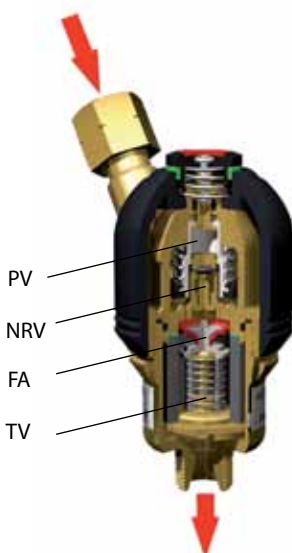

#### NON-RETURN VALVE (NRV)

Device which prevents the passage of gas in the opposite direction to normal flow. NRV is an essential unit preventing gas back flow.

#### FLAME ARRESTOR (FA)

Unit designed to extinguish fire and stop burning propagation by high heat dissipation when passing internal FBA sintered filter. A negative feature of every sintered Flame Arresting filter is flow restriction and pressure drop which gets worse when the filter gets clogged by gas impurities or burning products.

#### TEMPERATURE-SENSITIVE CUT-OFF VALVE (TV)

Device which stops gas flow if the surrounding or internal temperature reaches a specific level. The flow is stopped by a spring valve actuated by the melting of a thermal fuse and is not resettable.

#### PRESSURE SENSITIVE CUT-OFF VALVE (PV)

Device which stops the gas flow in case of a reverse-pressure wave travelling upstream through the system towards FBA. The pressure sensitive valve on a GCE FBA is resettable.

Check valves and FBA are not designed to substitute proper practice for safe operation. Thorough training and 100% focus on operation is irreplaceable. All the same a flashback arrestor – if properly chosen and installed effectively prevents a flashback from invading the gas supply system or cylinder.



## HOSE CHECK VALVES



Hose check valves prevent the reverse flow of gases beyond the torch inlets. GCE hose check valves are manufactured to our own approved design and the unique method of assembly eliminates the use of soldered or bonded joints. They are suitable to use with Oxygen, Acetylene, Propane or Natural Gas and operate effectively on either nozzle mix or injector type torches. Maximal working pressure of BV12 checkvalves is 15 Bar which makes products suitable even for heavy-duty applications like flame straightening or machine cutting torches. BV12 checkvalves are recommended to be used in combination with 2 or 3-function GCE flashback arrestors applied on the regulator side of the hose.

Art. Nr.	Gas		Safety functions	Max operation pressure	Connection thread	Weight
0764142	OXY	BV12 HCV G1/4" x 6.3 RH	1-functions - NRV	15 bar	G 1/4" RH	0.08 kg
0764141	FUEL	BV12 HCV G1/4" x 6.3 LH	1-functions - NRV	15 bar	G 1/4" LH	0.08 kg
0764144	OXY	BV12 HCV G3/8" x 6.3 RH	1-functions - NRV	15 bar	G 3/8" RH	0.10 kg
0764143	FUEL	BV12 HCV G3/8" x 6.3 LH	1-functions - NRV	15 bar	G 3/8" LH	0.10 kg
0764146	OXY	BV12 HCV G3/8" x 8 RH	1-functions - NRV	15 bar	G 3/8" RH	0.12 kg
0764145	FUEL	BV12 HCV G3/8" x 8 LH	1-functions - NRV	15 bar	G 3/8" LH	0.12 kg
0764148	OXY	BV12 HCV G3/8" x 10 RH	1-functions - NRV	15 bar	G 3/8" RH	0.15 kg
0764147	FUEL	BV12 HCV G3/8" x 10 LH	1-functions - NRV	15 bar	G 3/8" LH	0.15 kg

Torch mounted

## FR20 - 2 FUNCTION FLASHBACK ARRESTORS



FR20 is a robust but lightweight torch flashback arrestor specially designed for torch fitting. Its all-brass design and high-grade soft sealing elements makes FR20 fully compatible with all common technical gases. The unit incorporates the following features:

- FA SINTERED FLASH ARRESTOR element to quench a flashback.
- NV NON-RETURN VALVE to prevent reverse flow of gases.

High capacity sintered metal filter prevents foreign matter entering the unit but guarantees capacity enough for all manual and medium-duty machine cutting applications. All FR20 flashback arrestors conform to EN 730.

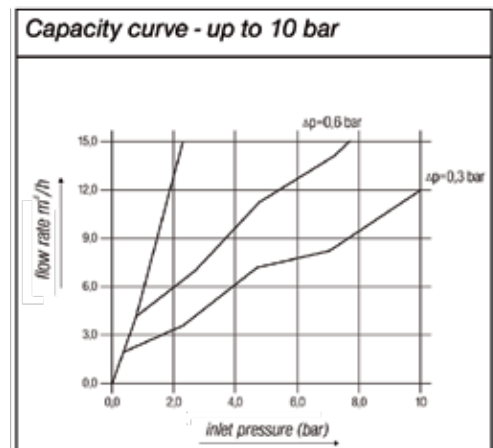
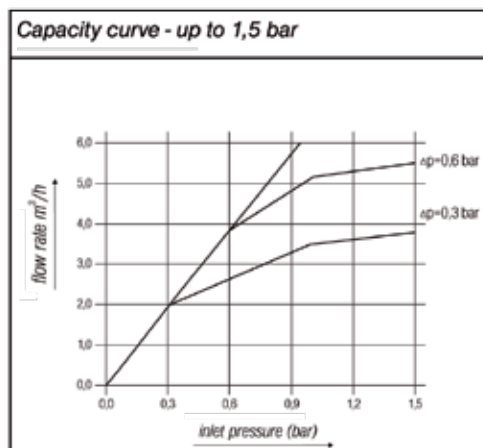

Art. Nr.	Gas		Safety functions	Max operation pressure	Connection thread	Weight
0764426	OXY	FBA FR-20T OXY G1/4"RH	2-functions - NRV, FA	10 bar	G 1/4" RH	0.13 kg
0764427	FUEL	FBA FR-20T FUEL G1/4"LH	2-functions - NRV, FA	5 bar*	G 1/4" LH	0.13 kg
0762256	OXY	FBA FR-20T OXY G3/8"RH	2-functions - NRV, FA	10 bar	G 3/8" RH	0.13 kg
0762257	FUEL	FBA FR-20T FUEL G3/8"LH	2-functions - NRV, FA	5 bar*	G 3/8" LH	0.13 kg

\* ACE / 1.5 bar  
Torch mounted

## FR34 - 3 FUNCTION FLASHBACK ARRESTORS

The FR34 flashback arrestors are basic models of 3-function FBA designed to be mounted on the regulator side. Flow capacity of FR34 is sufficient for a whole range of manual cutting or welding applications and even for basic machine cutting up to 200 mm. These arrestors fully comply with EN730 and ISO 5175. FR34 offer three safety functions:

- FA Sintered flame arresting element
- NV Non return valve to prevent reverse flow of gases
- TV Thermal trip device, activated by heat to permanently cut off the gas supply.

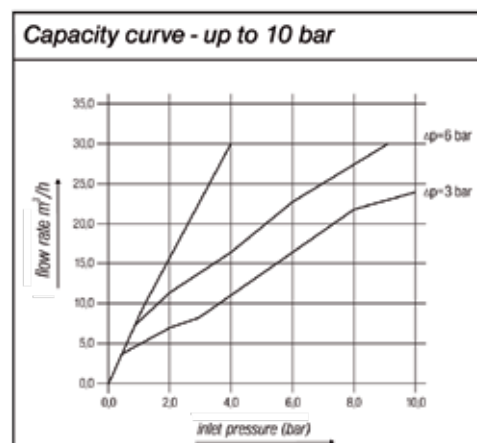
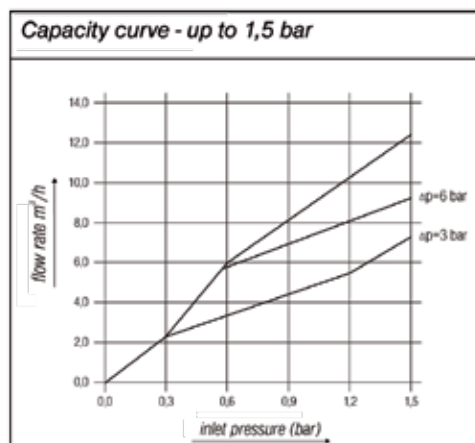

Art. Nr.	Gas		Safety functions	Max operation pressure	Connection thread	Weight
14008401	OXY	FBA FR-34R OXY G3/8" RH	3-functions - NRV, FA, TV	15 bar	G 3/8 RH	0.16 kg
14008402	FUEL	FBA FR-34R FUEL G3/8" LH	3-functions - NRV, FA, TV	5 bar*	G 3/8 LH	0.16 kg

\* ACE / 1.5 bar, H / 3.5 bar  
Regulator mounted

## FR91N - 3 FUNCTION HIGH FLOW FLASHBACK ARRESTORS

The FR91N are for regulator mounting and have been redesigned incorporating an improved sintered filter and thermal trip device. Complies with EN730.

- FA Sintered flame arresting element
- NV Non return valve to prevent reverse flow of gases
- TV Thermal trip device, activated by heat to permanently cut off the gas supply.

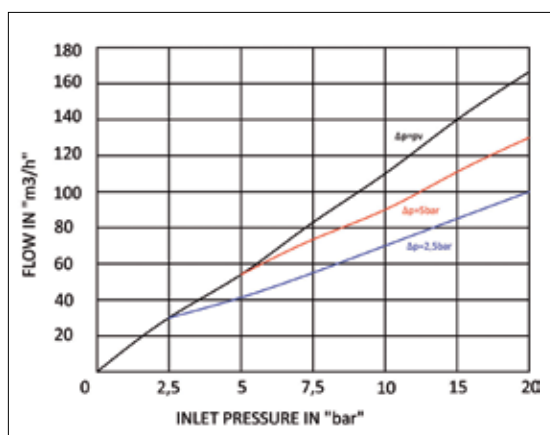
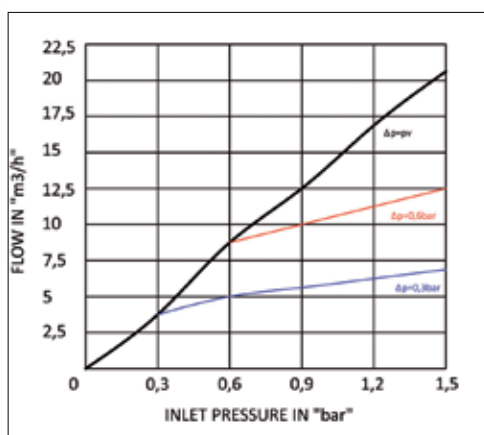

Art. Nr.	Gas		Safety functions	Max operation pressure	Connection thread	Weight
0764431	OXY	FBA FR-91N OXY G3/8" RH	3-functions - NRV, FA, TV	15 bar	G 1/2 RH	0.35 kg
0764430	FUEL	FBA FR-91N FUEL G3/8" LH	3-functions - NRV, FA, TV	5 bar*	G 1/2 LH	0.35 kg

\* ACE / 1.5 bar, H / 4 bar  
Regulator mounted

## FR50 - 4 FUNCTION HIGH FLOW FLASHBACK ARRESTORS



A regulator mounted safety device suitable for all welding and cutting operations, fully complying with EN730, this „lift to reset“ unit incorporates the following features:

- FA Sintered flame arresting element
- NV Non return valve to prevent reverse flow of gases
- PV Pressure trip device, activated by pressure wave accompanying a flashback
- TV Thermal trip device, activated by heat to permanently cut off the gas supply
- SI Status indicator shows green when unit is ready for use. In the event of a flashback the item can be reset by lifting and releasing the bonnet.

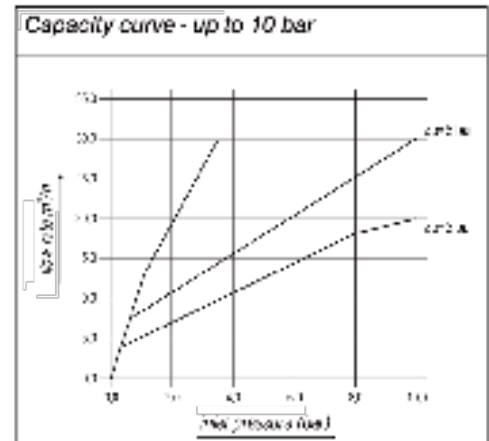
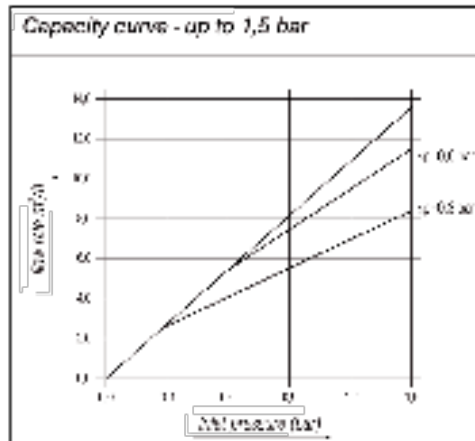

Art. Nr.	Gas		Safety functions	Max operation pressure	Connection thread	Weight
<b>0764423</b>	OXY	FBA FR-50 OXY G1/4" RH	4-functions**	11 bar	G 1/4" RH	0.55 kg
<b>0764424</b>	OXY	FBA FR-50 OXY G3/8" RH	4-functions**	10 bar	G 3/8" RH	0.55 kg
<b>0764425</b>	FUEL	FBA FR-50 FUEL G3/8" LH	4-functions**	5 bar*	G 3/8" LH	0.55 kg

\* ACE / 1.5 bar  
 \*\* NRV, FA, TV, PV  
 Regulator mounted

## DEMAX/SIMAX - 3 FUNCTION MANIFOLD FLASHBACK ARRESTORS



The manifold (line) flashback arrestors of the SIMAX and DEMAX family are products specially designed to provide maximal flow rate with minimal pressure drop necessary for central gas manifolds or cylinder bundle supply systems. Enormous flow capacity without any compromising of safety is achieved by the splitting of massive gas flow into several sections protected by individual flame arresting units. Sintered stainless steel filters in every unit provide flame arresting function, each of them is fitted by reliable non-returning valves and integrated thermal (melting) fuses. Individual units are arranged into compact clusters fitted by connection flanges allowing easy integration in to manifold pipelines.

Many other higher capacity variants (SIMAX 5/8...) are available on request.

To reach optimal performance and before choosing and purchasing GCE recommend consulting our experts who can give advice on your individual application.

Complies with EN730, German BAM institute tested.

SIMAX / DEMAX offers following safety functions:

- FA Sintered flame arresting element
- NV Non return valve to prevent reverse flow of gases
- TV Thermal trip device, activated by heat to permanently cut off the gas supply.

Art. Nr.	Gas		Safety functions	Max operation pressure	Connection thread	Weight
<b>0764433</b>	OXY	FBA DEMAX-5 OXY G1/2" RH	3-functions - NRV, FA, TV	15 bar	G1/2"RH	1.45 kg
<b>0764432</b>	FUEL	FBA DEMAX-5 FUEL G1/2" LH	3-functions - NRV, FA, TV	5 bar *	G1/2"LH	1.45 kg
<b>0764435</b>	OXY	FBA SIMAX-3 OXY G1" RH	3-functions - NRV, FA, TV	15 bar	G 1"RH	3.55 kg
<b>0764434</b>	FUEL	FBA SIMAX-3 FUEL G1" LH	3-functions - NRV, FA, TV	5 bar*	G 1"RH	3.55 kg

\* ACE / 1.5 bar  
 Application: Manifold / Pipeline





## TORCHES AND NOZZLES



## GCE COMBINED TORCHES AND CUTTERS

GCE combined torches and cutters are produced according to international standard EN ISO 5172. All product development in GCE is fully focused on safety, high performance and quality. GCE only use high-grade materials and skilled professionals to provide high quality products in order to meet all customer requirements and needs. Our aim is to help our customers succeed in high demand cutting and welding businesses. GCE torches must fully pass through the tightness test by compressed air in a water bath without any leakage.

We at GCE are ready to help customers with special requirements and are happy to prepare solutions for unique applications such as heating, flame cleaning, surface hardening, etc.

As parts of our standard range of equipment we offer two universal combine torch outfits plus one single-purpose cutter complete with all important and useful accessories. For light duty applications we offer the Orbit universal shank combined with compatible welding and cutting attachments.

For medium duty applications GCE recommends the MK3 combined torch where all welding, cutting and heating attachments are available. As a solution for customers requiring a powerful oxy-fuel cutter we can provide the NM250 cutter with cutting capacity up to 300 mm. GCE also provides consumables (cutting and welding nozzles) for all the above mentioned equipment.



All our cutting equipment works on the extremely safe nozzle-mixing principle. This means that the highly explosive preheating mixture of oxygen and fuel gas (acetylene, propane or natural gas) is mixed in very small volume only within the cutting nozzle. This solution brings important safety advantages in case of backfire or flashback caused by uneven operation. Only a very small amount of the gas mixture within the nozzle can be ignited so it is almost impossible to destroy the cutting torch by this type of incident. Despite the nozzle mixing system providing an unprecedented level of flashback resistance, GCE still strongly recommend the use of flashback arrestors to protect the operator's health and safety.

### NOZZLE-MIXING SCHEME

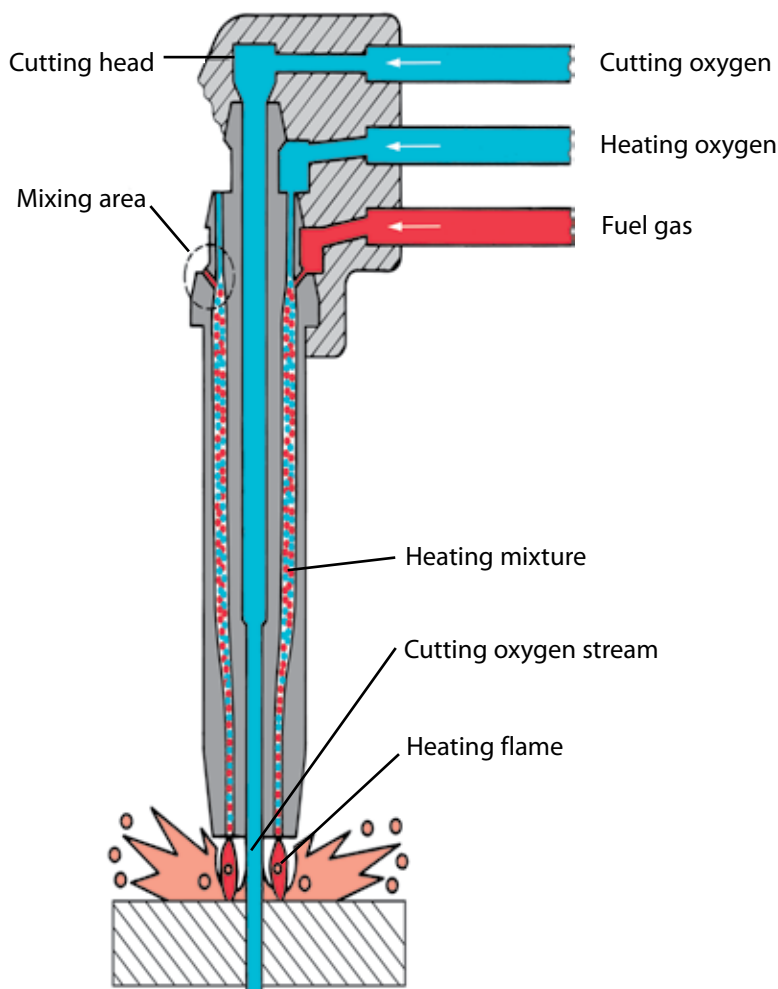

## LIGHTWEIGHT WELDING & CUTTING BLOWPIPE

### ORBIT

A superbly constructed welding & cutting blowpipe designed with safety in mind and engineered from highest quality materials to complement the operator in production or light gauge maintenance welding & cutting.

The shank is common to both welding and cutting heads, the same quick, positive and leak-free means of attachment being used for both. The shank is manufactured from a solid drilled aluminium forging thus avoiding the necessity of internal tubes and giving added safety.

#### WELDING AND HEATING

The shank can be used with any of the lightweight swaged nozzles enabling precise flame control and up to 8 mm (5/16") welding capacity in steel.

#### CUTTING

The newly designed lightweight cutting attachment uses the nozzle mix principle and is thus highly resistant to backfire and flashback.

Although of a lightweight design, it is engineered from solid brass castings and silver soldered tubes to provide an extremely robust construction. Using Orbit A-FN type nozzles and Acetylene fuel gas the orbit has a cutting capacity of over 20mm. Torches and nozzles conform to EN ISO 5172.



#### TECHNICAL DATA

Hose connections	1/4" BSP
Welding capacity	8 mm
Cutting capacity	20 mm
Welding nozzles	Lightweight, Swaged Nozzles Size 1-25 ... see page 38
Cutting nozzles	ORBIT A-FN Cutting Nozzles
	ORBIT A-SFN Sheet Metal Nozzles ... see page 37

Art. Nr.	Description
0766229	ORBIT shank
0766230	ORBIT cutting attachment
0766231	ORBIT mixer
9438170	ORBIT c/a nozzle nut

## MODEL "O" TYPE LIGHTWEIGHT BLOWPIPE



This extremely lightweight blowpipe has excellent balance and handling qualities. It can be used with either acetylene or hydrogen and is supplied complete with neck and a set of tips. Designed for very fine welding and brazing applications, including the fusion of thin gauge sheet metal up to 1.5mm (1/16") and lead welding. Suitable for jewellery, gold and silver work. Lead, zinc and thin section aluminium welding. Electrical and electronic engineering. Dental composition and repairs. Heating, ventilation and refrigeration work. Light fabrication and Laboratory work.

Art. Nr.	Description
47000	Standard model "O" blowpipe with neck & 5 tips
47666	Model "O" neck

### TECHNICAL DATA

Hose connections	1/4" BSP
Welding capacity	1,5 mm
Welding nozzles	Model "O" nozzle sizes 1-5 (Part N°47100-47500)

## ORBIT COMBINED WELDING & CUTTING OUTFIT



Art. Nr.	Description
81000	ORBIT combined outfit

### CONSISTING OF

- ORBIT Shank
- Mixer & Cutting Attachment
- L/W Nozzles Size 2, 5, 7, 10, 13, 18, 25
- 3/64" A-FN Type Cutting Nozzle
- Nozzle Cleaning Outfit
- Outfit Spanner
- Data Cards
- Plastic Carrying Case

## ORBIT L/W WELDING OUTFIT



Art. Nr.	Description
81903	ORBIT combined outfit

### CONSISTING OF

- ORBIT Shank
- Mixer
- L/W Nozzles Size 1, 2, 3, 5, 7, 10, 13, 25
- Hose Check Valves
- Outfit Spanner
- Data Cards
- Plastic Carrying Case

## CADDYPAK



The GCE CADDYPAK provides all the qualities of conventional Oxy-Acetylene welding cutting and heating without heavy cumbersome full size cylinders. Weighing only 33 Kgs it is totally portable making it ideal for many applications including:

- FARM REPAIRS
- CONSTRUCTION SITEWORK
- MOBILE REPAIR SERVICES
- FACTORY MAINTENANCE
- GARAGE & MOTOR TRADE
- DIY APPLICATIONS

The robust trolley has been re-designed to give added stability and has an adjustable height clamp to accommodate taller cylinders. Storage for the outfit case is provided on the rear of the trolley. The handle is retractable to enable the whole kit to be carried in a car boot.

The GCE ORBIT complete welding and cutting CaddyPak provides welding capacity up to 8mm (5/16") and cutting capacity up to 25mm (1") and heating with acetylene. Just add the cylinders and the kit is ready for immediate use.

N.B. CYLINDERS NOT INCLUDED. GCE torches and nozzles conform to BS EN ISO 5172.

### THE OUTFIT COMPRISES

ORBIT Shank, Mixer & Cutting Attachment, Single Stage, 2 Gauge Oxygen Regulator, Single Stage, 2 Gauge Acetylene Regulator, Slimguard Oxygen Flashback Arrestor, Slimguard Acetylene Flashback Arrestor, 5 Metres Twin Line Fitted Hose, L/W Nozzles Size 2, 5, 7, 10, 13, 3/64" A-FN Type Cutting Nozzle, ASFN Type Sheet Metal Cutting Nozzle, ORBIT Heating Nozzle & Neck, Sunfire Sparklighter, Nozzle Cleaner Outfit, Outfit Spanner, Combination Spanner, Goggles, Data Card, Plastic Carrying Case, CaddyPak Cylinder Trolley

Art. Nr.	Description
81789	CaddyPak



## MK 3A/4/5

### MK 3A/4/5 COMBINED WELDING & CUTTING TORCH FOR MEDIUM DUTY APPLICATIONS

The GCE MK3A /4/5 is a high pressure, sturdily constructed and well balanced welding and cutting torch. Each component (shank, mixer, cutting attachment) is inter-changeable with other leading makes of type 3/4/5 equipment. It has front mounted colour coded control valves, employing stainless valve spindles fitted with both 'O' ring and nylon seals; providing fine adjustment and leak-free conditions. The shank is common to both welding and cutting heads, the same quick positive positioning and leak-free means of attachment being used for both. GCE torches and nozzles conform to EN ISO 5172.

#### WELDING AND HEATING

Designed for welding work from 18swg to 8 mm thickness using type 3/4/5 swaged nozzles sizes 1 - 25. The mixer seats on serrated toothed faces allowing the operator a selection of positive nozzle positioning through 360°. Also can be used for heating, with either acetylene or propane heating nozzles, together with a heating neck.

#### CUTTING

The cutting head is nozzle mixing, enabling the operator to use either acetylene or propane fuel gases by fitting the appropriate nozzle. A range of ANM and PNM nozzles are available for clean efficient cutting of material thickness from sheet metal to 150 mm (6") using both acetylene and propane fuel gas. It's versatility allows gouging, flame cleaning etc., to be supplied to customer's requirements.

#### PROPANE SUPER HEATING

Using a propane super heating mixer and 255 mm (10") or 710 mm (28") stainless steel super heating neck an intense heat output of up to 180 kW (600,000 Btu/H) is obtained. Ideal for heating castings and similar large articles.

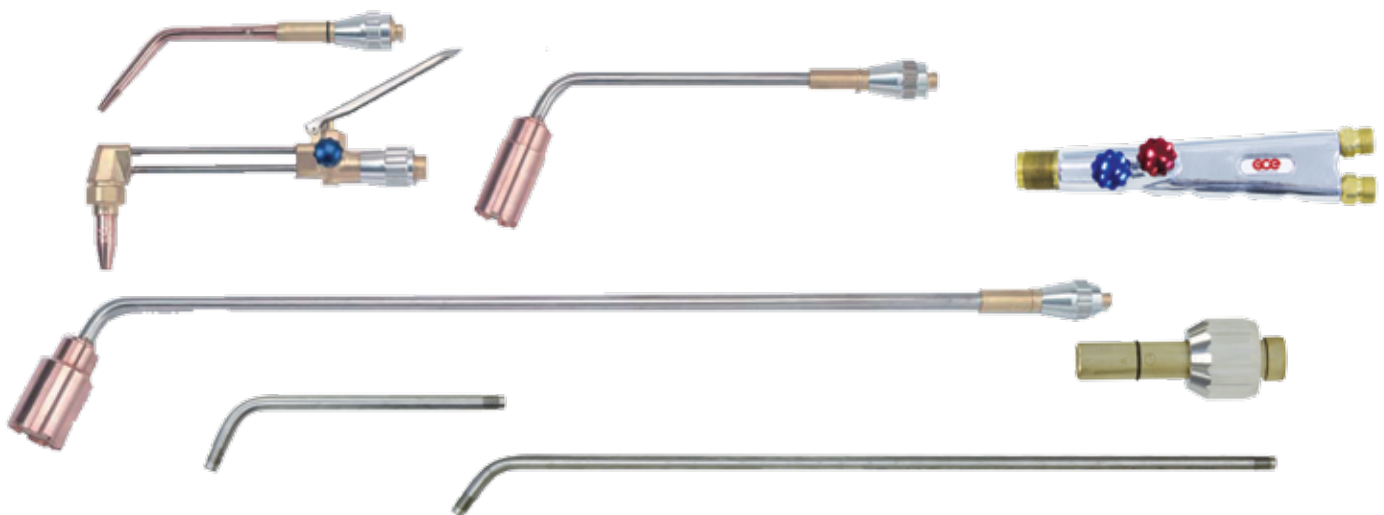

#### TECHNICAL DATA

Hose connection	G3/8"
Welding capacity	8 mm
Cutting capacity	150 mm
Welding nozzles	Type 2/3 Swaged Welding Nozzles Sizes 1-25 ... see page 38
Cutting nozzles	ANM (Acetylene) Cutting Nozzles ... see page 36
	PNM (Propane) Cutting Nozzles ... see page 36
	HA311-1 Sheet Metal Nozzles ... see page 37
	AGNM Gouging Nozzles ... see page 37
	ARCNM Rivet Cutting Nozzles ... see page 37
Super heating nozzles:	Super Heating Nozzles (Propane) Sizes 1H-5H ... see page 38

Art. Nr.	Description
0766241	MK 3A/4/5 shank
0766243	MK 3A welding mixer
0766253	MK 3A/4/5 propane superheating mixer
0766242	MK 3A/4/5 cutting attachment
0766254	255 mm (10") stainless steel super heating neck
0766255	710 mm (28") stainless steel super heating neck



## TYPICAL ASSEMBLIES - MK 3A/4/5 SYSTEM

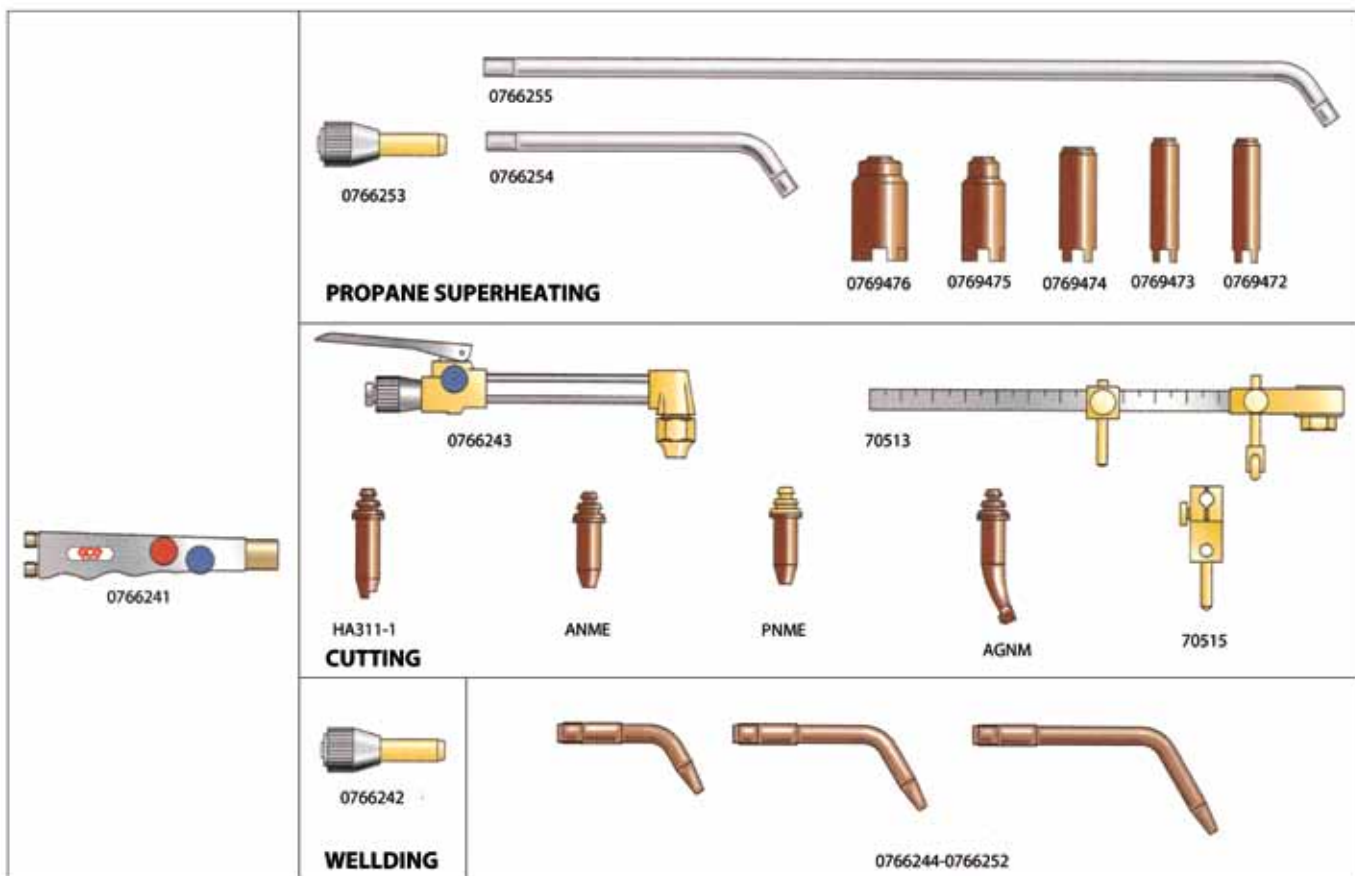

## MK3A/4/5 COMBINED WELDING & CUTTING OUTFIT



Art. Nr.	Description	Quantity
77000	MK 3A/4/5 combined outfit	1

### CONSISTING OF

- GCE MK 3A/4/5 Shank
- Cutting Attachment
- MK 3A welding mixer
- Type 3 Swaged Welding Nozzles Size 2, 5, 7, 10, 13, 18, 25
- 1/16" ANM Cutting Nozzle
- 3/64" ANM Cutting Nozzle
- Nozzle Cleaner Outfit
- Headnut Spanner
- Data Card
- Plastic Carrying Case

## UNIVERSAL NM250

GCE cutters are engineered from solid brass stampings with silver soldered joints and provide a lightweight, well balanced, durable cutter giving reliability.

With rear mounted valves and cutting lever and round handle.

Cutter employs the nozzle mix principle, in which the combustible gas mixing is confined to the cutting nozzle. This results in a cutter which is highly resistant to backfire and flashback. A wide range of accessories are available for this cutter, such as attachments for heating, gouging, sheet metal nozzles, circle attachments, etc., to give maximum possible versatility. GCE torches and nozzles conform to EN ISO 5172.

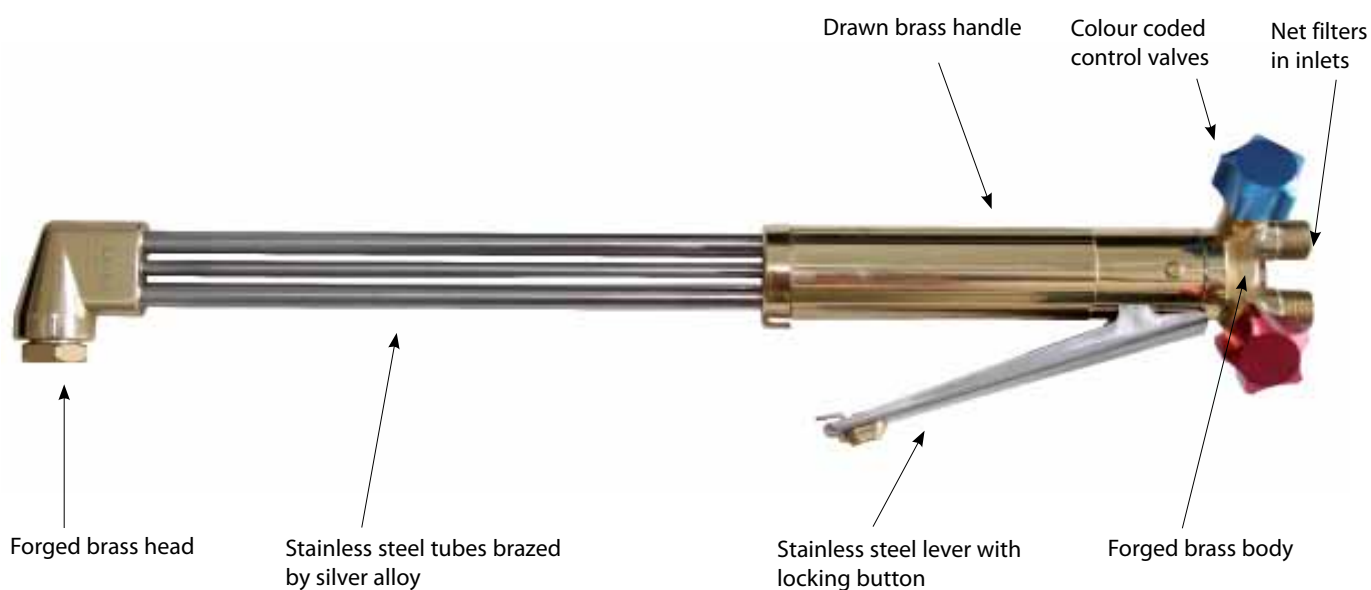

Art. Nr.	Description	Head Angles	Weight
0766225	460 mm (18")	90°	1,25 kg
0766226	700 mm (27")	90°	1,4 kg
0764510*	855 mm (33")	90°	1,5 kg
0764511*	1150 mm (45")	90°	1,8 kg

\* Upper lever

### TECHNICAL DATA

Hose connections	G3/8" - G3/8" LH
Cutting capacity	300 mm (12")
Cutting nozzles	ANME (Acetylene) Cutting Nozzles
	PNME (Propane) Cutting Nozzles
	HA311-1 Sheet Metal Nozzles
	AGNM Gouging Nozzles
	ARCNM Rivet Cutting Nozzles
Gas	Acetylene or Propane

## CUTTING TORCH ACCESSORIES

### DOUBLE ROLLER GUIDE



Steady and guide your torch over large plates and forgings. Fits all nozzle-mix cutters using ANM/PNM type nozzles. Fixed by clamping around nozzle thus accommodating either 75 or 90 torch heads.

Art. Nr.	Description
70510	Double roller guide

### LARGE CIRCLE CUTTING ATTACHMENT



Cut accurate circles with this versatile attachment. It is adjustable to cut circles from 60 mm (2 1/2") up to 425 (17") Dia.

Art. Nr.	Description
70513	Large circle cutting attachment

### SMALL CIRCLE CUTTING ATTACHMENT



For cutting smaller diameter circles, clamps to tubes of cutter or cutting attachment.

Art. Nr.	Description
70514	Small circle cutting attachment

### CUTTER HEAD NUTS



For use with NM250 cutters and type 3/4/5 cutting attachments.

Art. Nr.	Description
9427210	Head nut 7/8" * 20 UNS

## WELDING TORCH JETSOUND

This torch is light and easy to handle; it has been developed specifically for refrigerator technicians and installers of airconditioning equipment, who require a torch to be easy to handle for reaching narrow hard to get at points. JETSOUND torch allows a reduction in the movement of the operator's wrist. People who have already used the JETSOUND torch appreciate its perfect flame regulation and low flow-rates, thanks to the possibility of regulating oxygen flow by means of a pin (microregulation). This means that the attachment and the knob are on the same axis.



Art. Nr.	Fuel gas	Connections	Lenght	Weight
0766277	Acetylene	G1/4" / G1/4" LH	360 mm	0,51 kg

### JETSOUND ACCESSORIES

No	Product	Pack	Position
548800100112	Nozzles for welding (6 pcs) - Acetylene	1 piece	2
548800100122	Nozzles for welding (6 pcs) - Propane	1 piece	2
97825	Double flame attachment	1 piece	3
A290270EMB	Flexible welding attachment 160 l/h	1 piece	4
A290271EMB	Flexible welding attachment 250 l/h	1 piece	4
A290272EMB	Flexible welding attachment 315 l/h	1 piece	4



Welding nozzles



Double flame attachment



Flexible welding attachment

Welding range (mm)	Nozzles consumption (l/h)	Pressures (bar)		
		Oxygen	Acetylene	Propane
0,4 - 0,5	40	1 - 1,5	0,2 - 0,5	0,1 - 0,4
0,6	63			
1	100			
1,5	160			
2,5	250			
3	315			
4	400			
5	500			

## CUTTING NOZZLES

### ANM SHORT PATTERN

6 heating holes, 76 mm long.  
Use: Acetylene fuel gas.

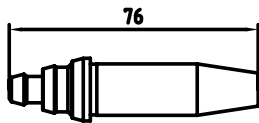

Art. Nr.	Range	Size	Quantity
0768554	3 - 6 mm	size 1/32"	1
0768555	5 - 12 mm	size 3/64"	1
0768556	10 - 75 mm	size 1/16"	1
0768557	70 - 100 mm	size 5/64"	1
0768558	90 - 150 mm	size 3/32"	1
076855	190 - 300 mm	size 1/8"	1

For cutting and setting data see please page 39.

### PNM SHORT PATTERN

9 spline inner, 76 mm long.  
Fuel gas: Propane

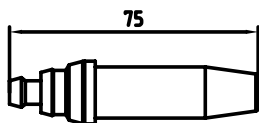

Art. Nr.	Range	Size	Quantity
0768880	3 - 6 mm	size 1/32"	1
0768865	5 - 12 mm	size 3/64"	1
0768879	10 - 75 mm	size 1/16"	1
0768878	70 - 100 mm	size 5/64"	1
0769481	90 - 150 mm	size 3/32"	1
0769482	190 - 300 mm	size 1/8"	1

For cutting and setting data see please page 39.

### ANME LONG PATTERN

6 heating holes, 88 mm long.  
Fuel gas: Acetylene

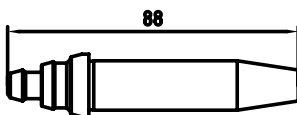

Art. Nr.	Range	Size	Quantity
0768670	3 - 6 mm	size 1/32"	1
0768635	5 - 12 mm	size 3/64"	1
0768599	10 - 75 mm	size 1/16"	1
0768636	70 - 100 mm	size 5/64"	1
0768662	90 - 150 mm	size 3/32"	1
0768598	140 - 200 mm	size 7/94"	1
0769041	190 - 300 mm	size 1/8"	1

For cutting and setting data see please page 39.

### PNME LONG PATTERN

9 spline inner, 88 mm long.  
Fuel gas: Propane

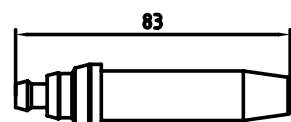

Art. Nr.	Range	Size	Quantity
0769494	3 - 6 mm	size 1/32"	1
0769495	5 - 12 mm	size 3/64"	1
0769496	10 - 75 mm	size 1/16"	1
0769497	70 - 100 mm	size 5/64"	1
0769498	90 - 150 mm	size 3/32"	1
0769499	140 - 200 mm	size 7/94"	1
0769501	190 - 300 mm	size 1/8"	1

For cutting and setting data see please page 39.



## AGNM GOUGING NOZZLES

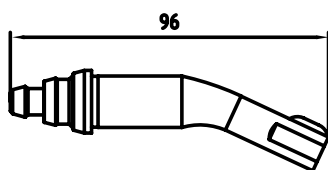

94 mm long.  
Fuel gas: Acetylene

Art. Nr.	Range	Size	Quantity
0768698	6 - 8 mm Width × 3 - 9 mm Depth	size 13 - 1/32"	1
0768661	8 - 11 mm Width × 6 - 11 mm Depth	size 19 - 3/64"	1
0768699	9 - 12 mm Width × 9 - 12 mm Depth	size 25 - 1/16"	1

For cutting and setting data see please page 39.

## HA311-1 SHEET METAL NOZZLE

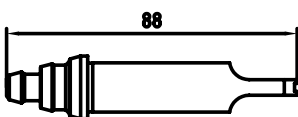

88 mm long.  
Fuel gas: Acetylene

Art. Nr.	Range	Size	Quantity
0768641	0 - 3 mm	0,3	1

For cutting and setting data see please page 39.

## ARCNM RIVET CUTTING NOZZLE

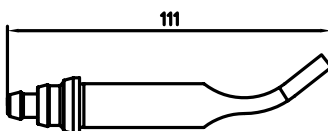

Fuel gas: Acetylene

Art. Nr.	Range	Size	Quantity
0769230	∅ 50 mm	1/16	1

For cutting and setting data see please page 39.

## AFN TYPE (ORBIT) CUTTING NOZZLES

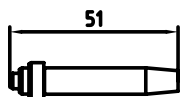

Fuel gas: Acetylene

Art. Nr.	Range	Size	Quantity
0769416	0 - 3 mm	Sheet Metal ASFN	1
0769285	3 - 6 mm	size 1/32"	1
0769287	6 - 20 mm	size 3/64"	1
0768825	20 - 30 mm	size 1/16"	1

For cutting and setting data see please page 39.

## MODEL 'O' BRASS WELDING TIPS



For use on Model 'O' Torch.

Art. Nr.	Size	Quantity
47100	size 1	1
47200	size 2	1
47300	size 3	1
47400	size 4	1
47500	size 5	1

## WELDING & HEATING NOZZLES

### ORBIT SWAGED COPPER NOZZLES

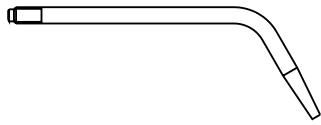

For use on Orbit torch 1/4" x 26 TPI thread.  
Fuel gas: Acetylene

Art. Nr.	Range	Size	Quantity
0766232	to 1 mm	size 1	1
0766233	1 - 1,5 mm	size 2	1
0766234	1,5 - 2 mm	size 3	1
0766235	2 - 2,5 mm	size 5	1
0766236	2,5 - 3 mm	size 7	1
0766237	3 - 4 mm	size 10	1
0766238	4 - 5 mm	size 13	1
0766239	5 - 6 mm	size 18	1
0766240	6 - 8 mm	size 25	1

For welding and setting data see please page 39.

### MK3 SWAGED COPPER TUBE NOZZLES

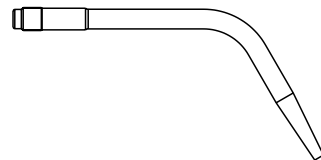

For use on Type 3/4/5 Welding torch 7/16" x 27 TPI Thread (Sizes 1-25 Type 2 & 3)  
Fuel gas: Acetylene

Art. Nr.	Range	Size	Quantity
0766244	to 1 mm	size 1	1
0766245	1 - 1,5 mm	size 2	1
0766246	1,5 - 2 mm	size 3	1
0766247	2 - 2,5 mm	size 5	1
0766248	2,5 - 3 mm	size 7	1
0766249	3 - 4 mm	size 10	1
0766250	4 - 5 mm	size 13	1
0766251	5 - 6 mm	size 18	1
0766252	6 - 8 mm	size 25	1

For welding and setting data see please page 39.

### SUPERHEATING NOZZLES



For use on type 3/4/5 blowpipe in conjunction with heavy duty mixer 0766253 and necks 0766254 or 0766255. Can also be used with NM250 in conjunction with superheating adaptor 0766256.  
Fuel gas: Propane

Art. Nr.	Size	Output	Quantity
0769472	1H	72 000 - 163 000 Btu/H	1
0769473	2H	102 000 - 188 000 Btu/H	1
0769474	3H	183 000 - 361 000 Btu/H	1
0769475	4H	236 000 - 406 000 Btu/H	1
0769476	5H	250 000 - 618 000 Btu/H	1
0766256	Superheating adaptor for NM Cutters		1

For heating and setting data see please page 39.



#### HOW TO FIT A SUPERHEATING ADAPTOR

Place the "three cone end" of the superheating adaptor into the torch head and fasten using the nozzle nut.

Once the adaptor is in place screw the superheating nozzle onto the adaptor.

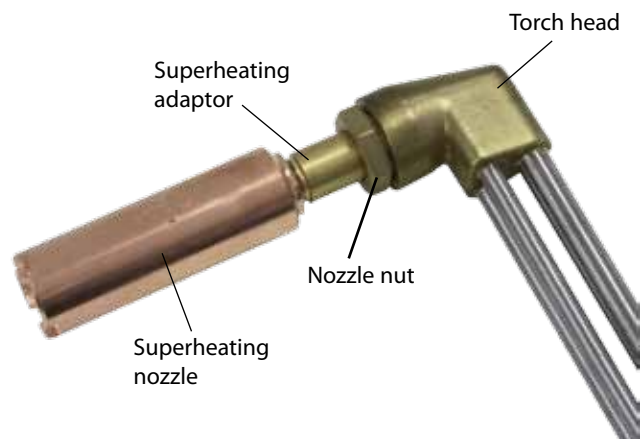

## WELDING, CUTTING & HEATING DATA

### WELDING / ORBIT & MK 3/A TORCHES

Mid Steel Tk'ness mm in swg	Nozzle size	Operating pressure				Gas consumption				
		Acetylene		Oxygen		Acetylene		Oxygen		
		bar	PSI	bar	PSI	l/h	ft <sup>3</sup> /h	l/h	ft <sup>3</sup> /h	
0,9	20	1	0,14	2	0,14	2	28	1	28	1
1,2	18	2	0,14	2	0,14	2	57	1	57	2
2	14	3	0,14	2	0,14	2	86	3	86	3
2,6	12	5	0,14	2	0,14	2	140	5	140	5
3,2	1/8 10	7	0,14	2	0,14	2	200	7	200	7
4	5/32 8	10	0,21	3	0,21	3	280	10	280	10
5	3/16 6	13	0,28	4	0,28	4	370	13	370	13
6,5	1/4 3	18	0,28	4	0,28	4	520	18	520	18
8,2	5/16 0	25	0,42	6	0,42	6	710	25	710	25
10	3/8 4/0	35	0,63	9	0,63	9	1000	35	1000	35
13	1/2 7/0	45	0,35	5	0,35	5	1300	45	1300	45
25	1+	90	0,63	9	0,63	9	2500	90	2500	90

### SUPER HEATING - PROPANE - MK 3/A & SUPER HEATING TORCHES

The flame size and heat output of these nozzles varies according to the pressure settings used. Two typical alternatives are given for each size of nozzle.

Nozzle Type	Propane pres.		Oxygen pres.		Propane cons.		Oxygen cons.		Heat output (app.)	
	bar	PSI	bar	PSI	l/h	ft <sup>3</sup> /h	l/h	ft <sup>3</sup> /h	W	Btu/h
1H	0,14	2	0,7	10	830	29	350	121	21101	72000
	0,49	7	2,1	30	1900	65	7300	255	47771	163000
2H	0,21	3	1,1	15	1200	41	4800	168	29893	102000
	0,46	8	2,5	35	2100	75	8700	304	55097	188000
3H	0,28	4	1,8	25	2100	75	8300	290	53632	183000
	1,1	15	5,0	70	4100	144	16500	575	105799	361000
4H	0,35	5	2,5	35	2700	94	10600	370	69165	236000
	1,3	18	5,7	80	4800	162	18800	650	118987	406000
5H	0,85	12	3,5	50	3200	112	12700	444	82353	281000
	2,1	30	8,7	125	7000	246	28000	964	181118	618000

### CUTTING - ACETYLENE - ORBIT TORCH

Material Tk'ness mm in	Nozzle size	Operating pressure				Gas consumption				Approx. Cutting Speeds				
		Oxygen		Acetylene		Cutting Ox		Heating Ox		Acetylene				
		bar	PSI	bar	PSI	l/h	ft <sup>3</sup> /h	l/h	ft <sup>3</sup> /h	l/h	ft <sup>3</sup> /h	mm/m	in/m	
3	1/8	S/M	2,1	30	0,3	4	650	30	120	4,5	220	8	110	4
6	1/4	1/32	2,1	30	0,15	2	710	25	255	9	255	8	255	8
20	3/4	3/64	2,1	30	0,15	2	1415	50	255	9	225	8	225	8
25	1	1/16	3,8	55	0,15	2	3400	120	255	9	225	8	225	8
50	2	1/16	5,3	75	0,20	3	4530	60	310	11	285	10	285	10

### CUTTING - ACETYLENE - MK 3/A & 18/90 CUTTERS (ANM NOZZLES)

Material Tk'ness mm in	Nozzle size	Operating pressure				Gas consumption				Approx. Cutting Speeds				
		Oxygen		Acetylene		Cutting Ox		Heating Ox		Acetylene				
		bar	PSI	bar	PSI	l/h	ft <sup>3</sup> /h	l/h	ft <sup>3</sup> /h	l/h	ft <sup>3</sup> /h	mm/m	in/m	
Sheet	ASNM	1,5	20	0,14	2	800	28	85	3	85	3	-	-	
6	1/4	1/32	1,8	25	0,14	2	800	28	480	15	400	14	510	20
13	1/2	3/64	2,1	30	0,21	3	1900	67	570	20	510	18	480	19
25	1	1/16	2,8	40	0,14	2	4000	140	540	19	470	17	400	16
50	2	1/16	3,2/3,5	45/50	0,14	2	4500	160	620	22	560	19	300	12
75	3	1/16	3,5/4,2	50/60	0,14	2	4800	170	680	24	620	22	205	8
100	4	5/64	3,2/4,8	45/70	0,14	2	6800	240	850	30	790	27	150	6
150	6	3/32	3,2/5,5	45/80	0,21	3	9400	330	960	34	850	30	125	5
200	8	1/8	4,2	60	0,28	4	14800	510	1380	48	1250	44	100	4
250	10	1/8	5,3	75	0,28	4	21500	760	1560	55	1420	50	75	3
300	12	1/8	6,3	90	0,28	4	25000	880	1560	55	1420	50	50	2

### GOUGING - MK 3/A & 18/90 CUTTERS (AGNM NOZZLES)

Material Tk'ness mm in	Nozzle size	Operating pressure				Gas consumption				Approx. Cutting Speeds				
		Oxygen		Acetylene		Cutting Ox		Heating Ox		Acetylene				
		bar	PSI	bar	PSI	l/h	ft <sup>3</sup> /h	l/h	ft <sup>3</sup> /h	l/h	ft <sup>3</sup> /h	mm/m	in/m	
8	5/16	13	4,0	60	0,5	7	3680	130	990	35	905	32	610	24
11	7/16	19	5,0	75	0,5	7	9340	330	1870	66	1700	60	1970	42
12	1/2	25	5,5	85	0,55	8	16270	575	2290	81	2100	74	1220	48

### CUTTING - PROPANE - MK 3/A & 18/90 CUTTERS (PNM NOZZLES)

Material Tk'ness mm in	Nozzle size	Operating pressure				Gas consumption				Approx. Cutting Speeds				
		Oxygen		Propane		Cutting Ox		Heating Ox		Propane				
		bar	PSI	bar	PSI	l/h	ft <sup>3</sup> /h	l/h	ft <sup>3</sup> /h	l/h	ft <sup>3</sup> /h	mm/m	in/m	
6	1/4	1/32	2,1	30	0,2	3	1000	36	1300	48	300	12	430	17
13	1/2	3/64	2,1	30	0,2	3	1800	65	1600	57	300	14	360	14
25	1	1/16	2,8	40	0,2	3	3000	140	1700	62	400	15	280	11
50	2	1/16	3,2	45	0,3	4	4500	160	1800	66	400	16	205	8
75	3	1/16	3,5	50	0,3	4	4800	170	2000	73	500	18	205	8
100	4	5/64	3,5	50	0,3	4	7300	260	2600	93	600	23	152	6
150	6	3/32	4,2	60	0,4	6	12300	435	3300	120	800	30	125	5
250	10	1/8	5,6	80	0,6	8	22300	790	4600	165	1100	42	50	2
300	12	1/8	6,7	95	0,8	8	26300	930	5900	210	1400	50	50	2

1. Data is for guidance only and may vary with operating conditions, materials etc.
2. Gas pressures are shown in BAR- 1 bar - 1 kg cm<sup>2</sup> and 1 PSI - 0,069 bar.
3. Gas consumption in LITRES PER HOUR (l/h) and Cubic feet/hour.

## STRAIGHTENING, CLEANING AND HEATING TORCHES SHANKS

### SP22 SHANK FOR HIGH FLOW TORCHES



Maximum flow 30 m<sup>3</sup>/h, connections: OX G3/8", Fuel gas G1/2"LH

**Art. Nr.**

**14025229**

#### TECHNICAL DATA

<b>Connecting thread</b>	W27 x 20 Gg
<b>Shaft Ø (mm)</b>	22

### SP22 SHANK FOR HIGH FLOW TORCHES WITH STATIC APPLICATION



Maximum flow 30 m<sup>3</sup>/h, connections: OX G3/8", Fuel gas G1/2"LH

**Art. Nr.**

**14025426**

#### TECHNICAL DATA

<b>Connecting thread</b>	W27 x 20 Gg
<b>Shaft Ø (mm)</b>	22

### ZEK-20 SHANK FOR STANDARD FLOW TORCHES WITH STATIC APPLICATION



Maximum flow 15 m<sup>3</sup>/h, connections: OX G1/4", Fuel gas G3/8"LH

**Art. Nr.**

**14046768**

#### TECHNICAL DATA

<b>Connecting thread</b>	W21,5 x 20 Gg
<b>Shaft Ø (mm)</b>	17

### ALUMINIUM SHANK FOR STANDARD FLOW HEATING TORCHES



Maximum flow 15 m<sup>3</sup>/h, connections: OX G1/4", Fuel gas G3/8"LH

**Art. Nr.**

**0767636** 14022100 Shank KOMBI 17

**0767632** 14078120 Shank RHÖNA 2001

#### TECHNICAL DATA

##### KOMBI 17

<b>Connecting thread</b>	W21,5 x 20 Gg
<b>Shaft Ø (mm)</b>	17

##### RHÖNA 2001

<b>Connecting thread</b>	W21,5 x 20 Gg
<b>Shaft Ø (mm)</b>	17

## OXY-ACETYLENE FLAME STRAIGHTENING TORCHES

Flame straightening is the use of a targeted flame to heat metal constructions. The metal is heated for a short time in very specific limited areas. This is only possible when high energy flames (heat flux) are used. The use of an oxy-acetylene flame is the best solution for this application. To be successful in the flame straightening process it is crucial to have a good understanding of material behaviour under heat.

### FLAME STRAIGHTENING TORCHES 3/2 FLAMES

Option to use 3 or 2 flames thanks to the independent shut off valve for one nozzle. Length 680 mm.

Suitable shank 0767632 (RHÖNA 2001)

Art. Nr.	Nozzle size
14070001	3
14070002	4



### FLAME STRAIGHTENING TORCHES 5/3 FLAMES

Option to use 5 or 3 flames thanks to the independent shut off valve for two nozzles. Length 680 mm.

Suitable shank 0767632 (RHÖNA 2001)

Art. Nr.	Nozzle size
14070003	3
14070004	4



### NOZZLES FOR STRAIGHTENING TORCHES



Art. Nr.	Nozzle size	Inner thread
14099881	3	M10 x 1,5
14099882	4	M10 x 1,5

#### TORCH PERFORMANCE DATA

Nozzle size	Acetylene pressure (bar)	Oxygen pressure (bar)	Acetylene consumption (m <sup>3</sup> /h)	Oxygen consumption (m <sup>3</sup> /h)
3	2,5	0,5	0,3	0,315
4	2,5	0,5	0,475	0,5



## CLEANING TORCHES

### CLEANING TORCHES OXY-ACETYLENE



Heating heads are one-row drilled.

The 250 mm torch comes standard with wheels to simplify usage.

Art. Nr.	Shank connection	Head width (mm)	Length (mm)
14014196	KOMBI 17	50	440
14014195	KOMBI 17	100	470
14014194	KOMBI 17	150	470
14014193	KOMBI 17	200	1117
14014192	KOMBI 17	250	1117

#### TORCH PERFORMANCE DATA

Head width (mm)	Oxygen pressure (bar)	Acetylene pressure (bar)	Oxygen consumption (m <sup>3</sup> /h)	Acetylene consumption (m <sup>3</sup> /h)
50	3	0,5	1,25	1
100	4	0,6	2,5	2
150	5	0,7	3,75	3
200	5	0,7	5	4
250	5	0,7	6,25	5

#### CAUTION:

When the torch head width is 100, 150, 200 and 250 mm acetylene consumption is too high for a single bottle.

Max acetylene supply from a 50-liter bottle = approximately 1 m<sup>3</sup>/h.

Reliable function of these torches is only guaranteed with a supply from an acetylene bundle!

### CLEANING TORCHES OXYGEN-PROPANE



Heating heads are three-row drilled.

Art. Nr.	Shank connection	Head width (mm)	Length (mm)m)
14014230	KOMBI 17	50	360
14014146	KOMBI 17	100	370
14014226	SP22	150	550
14014227	SP22	200	570
14014228	SP22	250	570

#### TORCH PERFORMANCE DATA

Head width (mm)	Propane pressure (bar)	Acetylene pressure (bar)	Oxygen consumption (m <sup>3</sup> /h)	Propane consumption (m <sup>3</sup> /h)
50	5	0,5	3,5	0,9
100	5	0,5	7,7	1,8
150	5	0,5	11,3	3,05
200	5	0,5	16,2	4,25
250	5	0,5	17,5	4,45

#### CAUTION:

When the torch head width is 100, 150, 200 and 250 mm propane consumption is too high for single bottle.

Max propane supply from a 33-kg bottle = approximately 1,6 m<sup>3</sup>/h.

Reliable function of these torches is only guaranteed with a supply from a propane bundle or tank!

## FLAME CLEANING

Flame cleaning is used as surface preparation for protective layers or coating applications to protect material against corrosion or other stresses. Flame cleaning is mainly used on steel structures, bridges, reservoirs as well as for use on concrete and natural stone.

Flame cleaning is thermal process engineering, using the oxy-acetylene flame acting in a specific mechanical-chemical way on steel surfaces to remove mill scale, rust, paint etc.

- The technological properties of steel are not changed
- Flame cleaning is environmentally friendly
- The cleaning process is reliable in any weather

Flame cleaning can easily be used for sheet thicknesses of 5 mm and above. Adequate gas supply is essential for the safe handling of flame cleaning torches!

### CAUTION:

When the torch head width is 100, 150, 200 and 250 mm acetylene consumption is too high for single bottle. Max acetylene supply from a 50-liter bottle = approximately 1 m<sup>3</sup>/h. Reliable function of these torches is only guaranteed with a supply from an acetylene bundle!

## HOW TO USE TORCH FOR CONCRETE CLEANING

Only an oxy-acetylene flame will provide best results if set up as shown below.

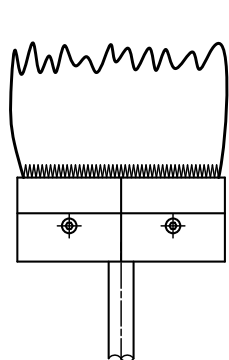

Neutral flame

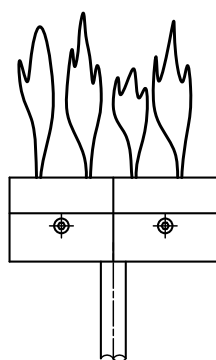

Flame with excess of oxygen.  
Flame colour is light blue.

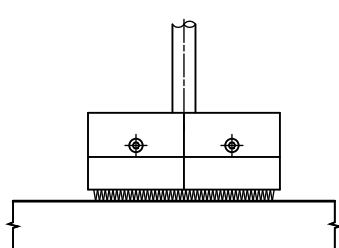

Right position

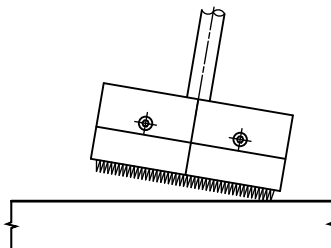

Wrong position

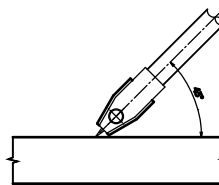

Right working angle

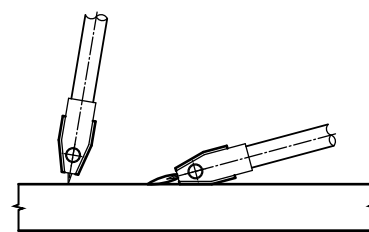

Wrong working angle

Bring the torch carefully towards the surface at a 45° inclination. The flame cone tips touch the surface.

## OXY-ACETYLENE HEATING TORCHES

DIN EN ISO 5172

### WARM UP / PREHEAT

The border between these two thermal processes is very narrow. Very often these are different names for the same job. To distinguish them we can define them as:

- Warming: material temperature increase for shaping
- Preheating: reaching or maintaining a certain temperature level

In both methods, the aim is to heat evenly throughout the material. The selection of gases depends on the technical requirements or the temperature to be reached. When choosing the type of gas to be used make sure to what extent condensed water vapor can have a negative influence (when using propane / natural gas).

Propane/natural gas torches with higher flow are noisier than acetylene torches with the same performance. The same applies to multi-slot nozzles compared to single channel nozzles.

### SHOWER HEATING TORCHES - ACETYLENE



Art. Nr.	Shank connection	Nozzle size	Lenght (mm)
14004175	RHÖNA 2001	4	240
14004176	RHÖNA 2001	6	240
14003283	RHÖNA 2001	6A	400
14004171	KOMBI 17	4	240
14004172	KOMBI 17	6	240
14003280	KOMBI 17	6A	400
14004179	RHÖNA 2001	7	670
14004180	RHÖNA 2001	9	670
14004161	KOMBI 17	7	670
14004162	KOMBI 17	9	670
14004185	SP 22	7	670
14004186	SP 22	9	670

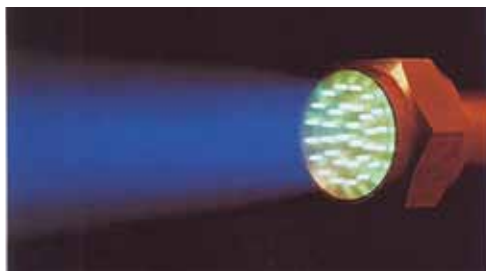

Flame picture for nozzle 7 and 9

### HIGH-PERFORMANCE ACETYLENE HEATING TORCHES

NEF / S size 12 and 13 with 12 flame channels with cooling and protective extension for heavy heating applications, e.g. for flame straightening of large steel structures



Art. Nr.	Shank connection	Nozzle size	Lenght (mm)
14004177	RHÖNA 2001	12	695
14004178	RHÖNA 2001	13	695
14004165	KOMBI 17	12	695
14004166	KOMBI 17	13	695
14004183	SP 22	12	750
14004184	SP 22	13	750



Flame picture for nozzle 12 and 13

## ACETYLENE HEATING NOZZLES



Nozzle size 4 and 6 with channel's location



Nozzle size 6A with channel's location



Nozzle size 7 and 9 with channel's location



Nozzle size 12 and 13 with channel's location

Art. Nr.	Typ	Nozzle size
14067532	NEF/B	4
14067535	NEF/B	6
14003224	NEF/B	6A
14004169	NEF/B	7
14004170	NEF/B	9
14004232	NEF/S	12
14004233	NEF/S	13

### TORCH PERFORMANCE DATA

Nozzle size	Oxygen pressure (bar)	Acetylene pressure (bar)	Oxygen consumption (m <sup>3</sup> /h)	Acetylene consumption (m <sup>3</sup> /h)
4	2,5	0,5	0,52	0,50
6	2,5	0,5	1,1	1,0
6A	2,5	0,5	1,8	1,7
7	3,0	0,5	2,3	2,15
9	3,0	0,5	4,3	4,1
12	2,5	0,5	3,8	3,75
13	2,5	0,5	4,4	4,3

### CAUTION:

When the torch head size is 6A, 7, 9, 12 and 13 acetylene consumption is too high for single bottle. Max. acetylene supply from a 50-liter bottle = approximately 1 m<sup>3</sup>/h. Reliable function of these torches is only guaranteed with a supply from an acetylene bundle!



## HEATING TORCHES PROPAN/NATURAL GAS - OXYGEN

These torches can be used for brazing all materials. For glass or quartz glass processing S-burners can be used successfully. A concentric primary flame provides the necessary performance. Surrounding secondary flame stabilizes the primary stream without performance restriction.

### HEATING TORCH S



Art. Nr.	Shank connection	Nozzle size	Lenght (mm)
14003700	RHÖNA 2001	1S	210
14003701	RHÖNA 2001	2S	240
14003702	RHÖNA 2001	3S	270
14003703	RHÖNA 2001	4S	310
14003704	RHÖNA 2001	5S	340
14003705	RHÖNA 2001	6S	380
14003109	KOMBI 17	1S	210
14003110	KOMBI 17	2S	240
14003111	KOMBI 17	3S	270
14003112	KOMBI 17	4S	310
14003096	KOMBI 17	5S	340
14003098	KOMBI 17	6S	380

Performance data and heating nozzle information you can see on page 47.



Flame picture for nozzle S

### HEATING TORCH DS

Torch DS is suitable for spot heating and flame straightening of steel structures. It could also be used where a narrow preheated area is required. The flame of the DS heating nozzle is very centralized and strong.



Art. Nr.	Shank connection	Nozzle size	Lenght (mm)
14003706	RHÖNA 2001	DS1	380
14003707	RHÖNA 2001	DS2	410
14003708	RHÖNA 2001	DS3	510
14003709	RHÖNA 2001	DS4	660
14003212	KOMBI 17	DS1	380
14003213	KOMBI 17	DS2	410
14003214	KOMBI 17	DS3	510
14003215	KOMBI 17	DS4	660
14027916	SP22	DS5	760
14027917	SP22	DS6	760

Performance data and heating nozzle information you can see on page 47.

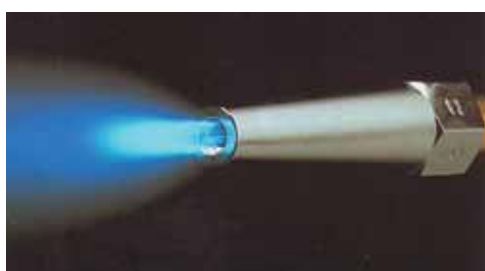

Flame picture for nozzle DS



## HEATING TORCH D

Torch D is suitable for the heating of steel structures with an extremely powerful flame.



Art. Nr.	Shank connection	Nozzle size	Length (mm)
14003710	RHÖNA 2001	D1	290
14003711	RHÖNA 2001	D2	490
14003712	RHÖNA 2001*	D3	650
14003182	KOMBI 17	D1	290
14003183	KOMBI 17	D2	490
14003184	KOMBI 17*	D3	650
14027209	SP22	D3	710
14027920	SP22	D4	710
14027210	SP22	D5	710

\* To guarantee maximum performance of D3 nozzles we recommend the use of a torch for shank SP22

Performance data and heating nozzle information you can see on page 47.



Flame picture for nozzle D

## HEATING TORCH DK

Torch DK is the best choice for the heating of steel structures with extremely concentrated flames.

The heating nozzle provides optimum heating time. This is made possible by high heat density of the gas supplied via a central channel surrounded by large slots around. Due to the large heat capacity of the DK torch it is highly recommended to use it in well ventilated areas.



Art. Nr.	Shank connection	Nozzle size	Length (mm)
14003713	RHÖNA 2001	DK2	490
14003714	RHÖNA 2001*	DK3	650
14003334	KOMBI 17	DK2	490
14003335	KOMBI 17*	DK3	650
14027336	SP22	DK3	710

\* To guarantee maximum performance of DK3 nozzles we recommend the use of a torch for shank SP22

Performance data and heating nozzle information you can see on page 47.

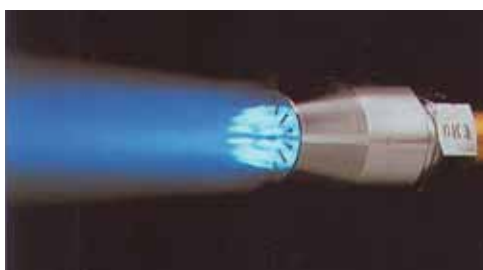

Flame picture for nozzle DK

## HEATING TORCH T

Torch T is suitable for surface heating with high flame power. It is very well suited for fast and efficient heating.



Art. Nr.	Shank connection	Nozzle size	Length (mm)
14003567	KOMBI 17	T2	490
14003568	KOMBI 17	T3	650
14003569	KOMBI 17	T4	650
14003564	RHÖNA 2001	T2	490
14003565	RHÖNA 2001	T3	650
14003566	RHÖNA 2001	T4	650
14027570	SP22	T5	710
14027571	SP22	T6	710

Performance data and heating nozzle information you can see on page 47.

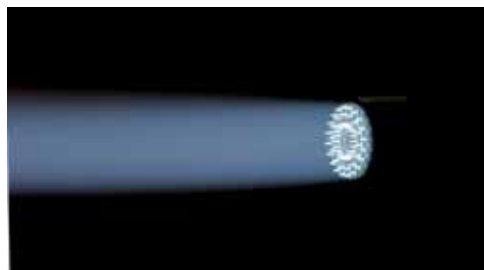

Flame picture for nozzle T

## HEATING TORCH TS - PROPAN/NATURAL GAS/MAPP/TETREN

Torch TS is recommended for spot heating and flame straightening at high flame stream performance and the use of alternative fuel gases



Art. Nr.	Shank connection	Nozzle size	Length (mm)
14003577	KOMBI 17	TS4	410
14003578	KOMBI 17	TS5	490
14003579	KOMBI 17	TS6	650
14003561	RHÖNA 2001	TS4	410
14003562	RHÖNA 2001	TS5	490
14003563	RHÖNA 2001	TS6	650
14027580	SP22	TS7	760
14027581	SP22	TS8	760

Performance data and heating nozzle information you can see on page 47.



Flame picture for nozzle TS

## HEATING NOZZLES S - CHROMIUM PLATED



Art. Nr.	Nozzle size
14003136	1S
14003130	2S
14003131	3S
14003132	4S
14003133	5S
14003134	6S



Nozzle S channel's location

Nozzle size	Oxygen pressure (bar)	Propane pressure (bar)	Oxygen consumption (m <sup>3</sup> /h)	Propane consumption (m <sup>3</sup> /h)
1S	3	0,4	0,31	0,09
2S	3	0,5	0,47	0,15
3S	4	0,5	1,2	0,36
4S	4,5	0,5	2,3	0,7
5S	5	0,5	3,3	1,03
6S	6	0,5	4,9	1,46

## HEATING NOZZLES DS - CHROMIUM PLATED



Art. Nr.	Nozzle size
14003220	DS1
14003221	DS2
14003222	DS3
14003223	DS4
14003918	DS5
14003919	DS6



Nozzle DS channel's location

Nozzle size	Oxygen pressure (bar)	Propane pressure (bar)	Oxygen consumption (m <sup>3</sup> /h)	Propane consumption (m <sup>3</sup> /h)
DS1	3	0,5	1,8	0,5
DS2	3	0,5	3,4	1,0
DS3	4	0,5	6,5	2,0
DS4	4,5	0,5	13,0	4,0
DS5	5	1,3	18,2	5,3
DS6	6	1,3	20,8	6,0

## HEATING NOZZLES D - CHROMIUM PLATED



Art. Nr.	Nozzle size
14003234	D1
14003235	D2
14003236	D3
14003921	D4
14003225	D5



Nozzle D channel's location

Nozzle size	Oxygen pressure (bar)	Propane pressure (bar)	Oxygen consumption (m <sup>3</sup> /h)	Propane consumption (m <sup>3</sup> /h)
D1	3	0,5	1,8	0,5
D2	5	0,5	6,5	2,03
D3	6	0,8/1,3	13,0/18,6	4,0/5,5
D4	6	1,3	21,6	6,2
D5	6	1,3	23	6,6

## HEATING NOZZLES DK - CHROMIUM PLATED

**Art. Nr.**

<b>14003332</b>	DK2
-----------------	-----

<b>14003333</b>	DK3
-----------------	-----

Nozzle size	Oxygen pressure (bar)	Propane pressure (bar)	Oxygen consumption (m <sup>3</sup> /h)	Propane consumption (m <sup>3</sup> /h)
DK2	5	0,5	6,5	2,03
DK3	6	0,8/1,3	13,0/18,6	4,0/5,5



Nozzle DK channel's location

## HEATING NOZZLE T - NON CHROMIUM PLATED

**Art. Nr.**

<b>14003572</b>	T2
-----------------	----

<b>14003573</b>	T3
-----------------	----

<b>14003574</b>	T4
-----------------	----

<b>14003575</b>	T5
-----------------	----

<b>14003576</b>	T6
-----------------	----

Nozzle size	Oxygen pressure (bar)	Propane pressure (bar)	Oxygen consumption (m <sup>3</sup> /h)	Propane consumption (m <sup>3</sup> /h)
T2	4	0,3	5,3	1,6
T3	4,5	0,3	11	3
T4	8	0,5	19	5,5
T5	4,5	0,5	27	7,7
T6	6	0,5	34	9,8

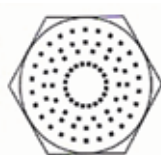

Nozzle T channel's location

## HEATING NOZZLE TS - NON CHROMIUM PLATED

**Art. Nr.**

<b>14003582</b>	TS4
-----------------	-----

<b>14003583</b>	TS5
-----------------	-----

<b>14003584</b>	TS6
-----------------	-----

<b>14003585</b>	TS7
-----------------	-----

<b>14003586</b>	TS8
-----------------	-----

Nozzle size	Oxygen pressure (bar)	Propane pressure (bar)	Oxygen consumption (m <sup>3</sup> /h)	Propane consumption (m <sup>3</sup> /h)
TS4	7	0,3	5,15	1,4
TS5	7	0,5	8,6	2,4
TS6	7	0,8	16	4,45
TS7	6	0,5	21,6	6
TS8	6	0,5	25,4	7,05



Nozzle TS channel's location

**CAUTION:**

When heating nozzle's propane consumption is higher than 1,5 m<sup>3</sup>/h a single bottle is not a reliable source.

Max propane supply from a 33-kg bottle = approximately 1,6 m<sup>3</sup>/h.

Reliable function of these torches is only guaranteed with a supply from a propane bundle or tank!







**PROPALINE**

## UNIVERSAL AIR PROPANE EQUIPMENT

Ideal for plumbing, heating, and ventilation trades, the GCE air propane shank has adjustable pilot flame and 3/8" BSP inlet. Spot/turbo(copper pipe)/special burners connect directly to the shank for all plumbing applications. Heating heads are connected via stainless tubes for larger heating jobs such as road working/roofing/bitumen heating.

### SHANK WITH GAS SAVER - UNIVERSAL



Combined shut-off valve and adjusting knob.  
Use: designed for use with soldering, brazing and heating torches UNIVERSAL

Art. Nr.	Torch, tube connection	Quantity
0763216	M14 × 1	1

#### TECHNICAL DATA

Working pressure	up to 4 bar
Adjustable pilot flame	
Capacity	12 kg/h
Length	195 mm
Weight	0,36 kg
Gas	PB
Hose connection	G 3/8" LH

### PAINT REMOVER FAN BURNER - UNIVERSAL



Use: for removing old work and localised heating.

Art. Nr.	Connection	Quantity
23705	M14 × 1	1

#### TECHNICAL DATA

Working pressure	1,5 - 2,0 bar
Consumption PB	220 g/h
Output	2,83 kW
Length/width	170/40 mm
Weight	0,19 kg

### SOLDERING TORCH B - UNIVERSAL



Use: for soldering and brazing; for point heating.

Art. Nr.	Connection	Type	Quantity
548800763223	M14 × 1	B-5 mm	1
548800763224	M14 × 1	B-7 mm	1

#### TECHNICAL DATA

	B-5 mm	B-7 mm
Working pressure	1,5 - 2,5 bar	1,5 - 2,5 bar
Consumption PB	54 - 66 g/h	162 - 210 g/h
Output	0,69 - 0,85 kW/h	2,08 - 2,70 kW/h
Length	120 mm	138 mm
Weight	0,09 kg	0,11 kg
Gas	P, PB	P, PB

## BRAZING TORCH TURBO - UNIVERSAL

Use: for soldering and brazing, especially of copper piping systems



Art. Nr.	Connection	Type	Quantity
548800763225	M14 × 1	T Ø12	1
4903	M14 × 1	T Ø14	1
4911	M14 × 1	T Ø17	1
548800763228	M14 × 1	T Ø20	1

### TECHNICAL DATA

	T Ø12	T Ø14	T Ø17	T Ø20
Working pressure	1,5 - 2,5 bar	1,5 - 2,5 bar	1,5 - 2,5 bar	1,5 - 2,5 bar
Consumption PB	63 - 112 g/h	210 - 338 g/h	272 - 384 g/h	440 - 550 g/h
Output	0,81 - 1,44 kW	2,70 - 4,35 kW	3,50 - 4,94 kW	5,66 - 7,08 kW
Length	155 mm	178 mm	184 mm	190 mm
Weight	0,13 kg	0,15 kg	0,17 kg	0,19 kg
Gas	P, PB	P, PB	P, PB	P, PB
For copper pipe	12 mm	18 mm	22 mm	28 mm

## HEATING TORCH GT - UNIVERSAL

Use: for heating of pipes 1/2" or 1"; for pipe soldering and brazing jobs; preheating before tube bending.  
Use with neck tube.



GT 1/2"

Art. Nr.	Connection	Quantity
548914094500	GT 1/2"	1
21089	GT 1"	1

### TECHNICAL DATA



GT 1"

	GT 1/2"	GT 1"
Working pressure	1,5 - 2,0 bar	1,5 - 2,0 bar
Consumption PB	350 g/h	450 g/h
Output	4,50 kW	5,79 kW
Length	190 mm	190 mm
Weight	0,20 kg	0,24 kg
Gas	P, PB	P, PB

## SHRINKWRAP TORCH S - UNIVERSAL

Use: available in two sizes for shrinkwrapping.



Art. Nr.	Connection	Quantity
32003	S - 30 mm	1
33670	S - 40 mm	1

### TECHNICAL DATA

	S - 30 mm	S - 40 mm
Working pressure	1,5 bar	1,5 bar
Consumption PB	1 900 g/h	2 500 g/h

## HEATING TORCH H - UNIVERSAL



Use: for industrial heating; roofing and construction work.  
Use with neck tube.

M20×1

Art. Nr.	Type	Quantity
548800763217	30 mm	1
548800763218	40 mm	1
4069	45 mm	1
548800763219	50 mm	1
548800763220	60 mm	1

### TECHNICAL DATA

	H Ø30	H Ø40	H Ø45
Working pressure	1,0 - 4,0 bar	1,0 - 4,0 bar	1,0 - 4,0 bar
Consumption PB	664 - 1056 g/h	1200 - 1902 g/h	2500 - 5300 g/h
Output	8,55 - 13,59 kW	15,44 - 24,48 kW	37,9 - 76,2 kW
Length	88 mm	90 mm	100 mm
Weight	0,12 kg	0,21 kg	0,25 kg
Gas	P, PB	P, PB	P, PB

	H Ø50	H Ø60
Working pressure	1,0 - 4,0 bar	1,0 - 4,0 bar
Consumption PB	3780 - 7590 g/h	5030 - 9744 g/h
Output	48,68 - 97,69 kW	64,74 - 125,41 kW
Length	115 mm	125 mm
Weight	0,30 kg	0,34 kg
Gas	P, PB	P, PB

## NECK TUBE - UNIVERSAL



Manufactured in stainless steel.

Use: designed to connect UNIVERSAL heating torches to shank UNIVERSAL. Head connection M 20×1 MALE. Torch connection M 14×1 FEMALE.

Art. Nr.	Type	Connection	Weight	Quantity
2279	130 mm	M14 × 1	0,11 kg	1
548809381300	230 mm	M14 × 1	0,14 kg	1
548809381310	350 mm	M14 × 1	0,19 kg	1
548809381310	500 mm	M14 × 1	0,25 kg	1
548809381320	600 mm	M14 × 1	0,29 kg	1
548809381330	750 mm	M14 × 1	0,35 kg	1
548809381340	1000 mm	M14 × 1	0,44 kg	1

## SUPPORT H-UNIVERSAL



Use: Allows hot heating torches to be rested safely on a horizontal surface. Assembled onto the neck tube of the torch.

Art. Nr.	Weight	Quantity
12476	0,15 kg	1



**ACCESSORIES**



## ACCESSORIES

### TUBE FLOWMETER



Precision Flowmeter with brass finish, G3/8" BSP connections. The tube flowmeter is designed to be used with either FIXICONTROL or UNICONTROL fix-preset regulators only. Working inlet pressure of Tube Flowmeter is 4.5 Bar.

Art. Nr.	Gas	Max inlet pressure	Nominal pressure	Nominal flowrate	Inlet connection	Outlet connection	Approx. weight
0764956	AR/CO <sub>2</sub>	4.5 bar	atm.	3-30 l/min	G 3/8 RH	G 3/8 RH	0.32 kg

### GAS ECONOMISER



Art. Nr.	Gas	Max inlet pressure	Inlet connection	Outlet connection	Approx. weight
0767916	OXY/ACE	10 bar	G 3/8" RH/LH	G 3/8" RH/LH	0.47 kg
0767917	OXY/PROP	4.5 bar	G 3/8" RH/LH	G 3/8" RH/LH	0.47 kg

### CLEANING NEEDLE



Art. Nr.  
548904225520

### CLEANING NEEDLES



Art. Nr.  
548814071191

### HOSE COUPLING



Art. Nr.	Type
4591690	G3/8"
4591680	G1/4"
4591750	G3/8" LH

### HOSE NIPPLE



Art. Nr.	Hose inner diameter	Connection nut size (nut not included)
4599380	Ø 6,3 mm	G1/4"
4184250	Ø 8 mm	G1/4"
4734980	Ø 6,3 mm	G3/8"
4599440	Ø 8 mm	G3/8"
4199960	Ø 10 mm	G3/8"

## OUTLET NUT



Art. Nr.	Thread size
4599400	G1/4"
4712020	G1/4" LH
548200018934	G3/8"
548200018932	G3/8" LH

## HOSE CLAMP



Art. Nr.
548900063518

## WRENCH



Art. Nr.	Type
163811144503	Nozzle wrench
163811966360	Multi-opening wrench

## SHIELDING GAS FLOWMETER



Art. Nr.	Type	Flow
548202227514	Argon/CO <sub>2</sub>	0-30 l/min

## LIGHTER



Art. Nr.	Type
54800003001B	Flint lighter
5480003001XC	Spare flint stone

## GAUGE PROTECTOR



Art. Nr.	Type
321814215000	Gauge core Ø 63 mm

## GCE QUALITY

### PROVEN QUALITY FOR BEST SAFETY PERFORMANCE

Safety is first priority, and that quality is essential for performance and optimal cost effectiveness. Our wide range of products and solutions is well established in the market, and recognised for its high safety and superior, consistent quality. Today's wide product portfolio corresponds to a large variety of applications. This brings wide complexity of technical problems and a need for extensive testing before introduction to the markets. All products are thoroughly type tested in well equipped GCE testing laboratories and many of them are even externally tested and certified by renowned Testing Institutes and notified bodies.

### FULL COMPLIANCE WITH STANDARDS AND NORMS

In addition to company certification conforming to the ISO 9000 quality standard, our products are tested and certified by BAM, BSI, Det Norske Veritas, US DOT, UL, CEN, DIN and SIS, among others. All sales units connected with medical products have EN approvals for CE marking and some have also been approved in accordance with the ISO 14000 environmental standard. We are also independently certified by many of our key customers.



GCE Group is one of the world's leading companies in the field of gas control equipment. The headquarters are in Malmö, Sweden, and the two major supply units are located in the Czech Republic and in China. The company operates 15 subsidiaries around the world and employs more than 850 people. GCE Group includes four business areas –Cutting & Welding, Process Applications, Medical and High Purity. Today's product portfolio corresponds to a large variety of applications, from single pressure regulators and blowpipes for cutting and welding to sophisticated gas supply systems for medical and electronics industry applications.



**GCE India Pvt Ltd**  
"Prem-Bagh" 1st floor  
31 Benson Road, Benson Town,  
Bangalore 560046, Karnataka, India  
Tel: +91 802 363 1685  
Fax: +91 802 363 1685  
gce.india@gcegroup.com  
www.gcegroup.com

**Sales office Mumbai:**  
Offices No. 44 & 45, 2nd Floor,  
Crystal Plaza, Hiranandani Complex,  
Sector - 7, Kharghar, Navi Mumbai  
410 210 Maharashtra, India  
Tel: +91 998 702 6546



Gas Control Equipment